

ULLRICH MARINE



www.ullrich.com.au • www.ullrich.co.nz

QUALITY • SERVICE • INTEGRITY

INTRODUCTION

ABOUT US

Ullrich Aluminium is a Trans Tasman aluminium extrusion manufacturer who specialise in the supply of aluminium extrusion, plate, sheet, treadplate, welding wire and rods, along with a wide range of stainless fasteners, sealants, adhesives and tapes to the Marine Industry in New Zealand and Australia.

PRODUCTS

The products covered in this catalogue reflects only the “popular” items and is in no way the full range. If you cannot find what you are looking for we recommend you view our website: www.ullrich.co.nz or www.ullrich.com.au

INFORMATION

The information contained in this catalogue is representative of the information available on our websites. Further information and technical advice is available by contacting any of our branch operations.

STOCK

Not all items may be available from branches around the country or from our distribution centres, we advise you check availability of each product at the time of inquiry particularly if you are specifying for a future build.

EXTRUSION QUALITY ASSURANCE

Ullrich Aluminium extrusion plant is a AS/NZS ISO 9001 - 2008 BUREAU VERITAS certified company (certificate number 900033). Ullrich Aluminium is certified to Lloyds Register to produce extrusion which require, Lloyds certification for the marine industry. Alloy range 6060, 6261, 6082, 6106.

ROLLED PRODUCTS QUALITY ASSURANCE

Ullrich aluminium has a reputation for supplying first rate, top quality plate and sheet for the marine industry, using only prime suppliers from Europe and the USA.

Marine Plate and sheet is stocked in DNV and Lloyds certification. ABS is available on indent or by external certification.

Ullrich Aluminium is the sole stockist and supplier of the ALCAN MARINE developed product SEALIUM.

Cover Image: 'Salperton' built by Fitzroy Yachts,
New Plymouth, New Zealand.

CONTENTS

SHEET & PLATE PAGE

Marine Sheet and Plate	2
Tooling Plate	2
Treadplate	3
Flat Sheet	3

TECHNICAL DATA PAGE

Sealium	Sheets and plates	4
----------------	-------------------	----------

EXTRUSIONS PAGE

Flat Bar	6
Extruded Round Tube	10
Tee	18
Sealium Tees and Bulbed Flats	24
Toe Rail	25
Chine	26
Gunnel	27
Rub Rails and Infills	28
Sail Track	30
Windscreen	31
Awning	32
Miscellaneous	33
Aluminium Marine Castings	34
Anodes	35
Aluminium Welding Wire - Welding Rods	36

**Phone for your nearest
ULLRICH ALUMINIUM SALES CENTRE**

AUSTRALIA - 1300 650 075 • **NEW ZEALAND - 0800 500 338**
www.ullrich.com.au • **www.ullrich.co.nz**



MARINE SHEET AND PLATE



TECHNICAL DATA

Substrate material Aluminium plate

Alloy and temper 5083-H321 5083 H112
5083-H116

Coatings and finishes Mill, PVC Coating upon request

Sheet size

Thickness range 3.00 4.00 5.00 6.00 8.00
10.00 12.00 16.00 20.00
25.00 32.00 40.00 50.00
60.00 75.00 100.00 140.00

Flat width x length 1200 x 2400 1200 x 4800
1200 x 6100 1200 x 7100
1350 x 2400 1350 x 6100
1525 x 6100 1525 x 8500
1830 x 6100
2000 x 2000
2000 x 8000

Standard compliance range DNV Lloyds ABS

Availability All main centres

Scope of use Marine hulls and components

TECHNICAL DATA

6061-T6 **Machining Plate**

Sheet size

Thickness range 12.00 16.00 20.00 25.00
31.75 40.00 50.80 60.00
80.00 101.60

Flat width x length 1200 x 2400
1500 x 2400
1231 x 3670

TOOLING PLATE



TECHNICAL DATA

7075-T651 **Tooling Plate**

Sheet Size

Thickness range 15.88 25.40 38.10 44.45
50.80 76.20 77.00 101.60

Flat width x length 2000 x 1000

How to calculate the weight of any sheet or plate
given aluminium base density of 2.71

1. Calculate weight per sq.m

Density x Mass x Thickness = weight per sq.m
ie: 2.71 X 1.00 X Thickness
eg: Weight of 1.6mm sheet per sq.m:
2.71 x 1.00 x 1.6 = 4.336 kg per sq.m

2. Multiply the weight per sq.m by the area of the sheet

eg: Weight of 1.6 x 1200 x 2400 sheet (2.88 sq.m)
4.336 x 2.88 = 12.487 kg

IMPORTANT INFORMATION

While all care has been taken in the production of this publication, Ullrich Aluminium Co Ltd does not accept responsibility for any inaccuracy or errors contained therein. Ullrich Aluminium Co Ltd cannot therefore be responsible for its accuracy or correctness.

The information and values are intended only as a general guide to performance and suitability for application. Nothing herein contained shall constitute a warranty that any product is specifically suitable for a particular purpose. Data is not intended for design.

TREADPLATE



TECHNICAL DATA

Sheet size

Thickness range	1.00	1.60	2.00	2.50	3.00
	4.00	4.50	5.00	6.00	8.00
Flat width x length	1200 x 2400		1200 x 2700		
	1200 x 3600		1200 x 4800		
	1200 x 6100				
	1500 x 4800		1500 x 6100		

FLAT SHEET



TECHNICAL DATA

5052-H32-H34

Flat Sheet

Sheet size

Thickness range	0.60	0.70	0.90	1.20	1.60
	2.00	2.50	3.00	4.00	5.00
	6.00	8.00	12.00		
Flat width x length	900 x 2400		750 x 3000		
	1200 x 2400		1200 x 3000		
	1200 x 3600		1200 x 4800		
	1200 x 6100				
	1500 x 3000		1500 x 3600		
	1524 x 2400		1830 x 2400		
		1830 x 6100			

IMPORTANT INFORMATION

Certain sheet types, grades and sizes may not always be available at all supply centres. Please enquire on stock availability before project commencement and we will endeavour to fulfill your order promptly from alternative sources.

Dimensions are shown in mm, are nominal and may vary with types and grades of material. Diagrams and illustrations are schematic only.





SEALIUM®

Sheets and plates

Description

This specification defines the properties and characteristics of Sealium® marine grade aluminium alloy, delivered by Alcan Marine as sheets or plates.

Created and registered by Alcan Marine, Sealium® optimises the overall productivity of shipbuilders and the performance of vessels in general as it makes them more robust, safer, and user-friendly.

In just a few years, Sealium® has become the international industry reference for fast ferries.

Chemical composition

%	Si	Fe	Cu	Mn	Mg	Cr	Zn	Ti	Zr	other (max.)
min.				0.7	4.0					each: 0.05
max.	0.25	0.25	0.20	1.0	5.2	0.25	0.40	0.15	0.20	total: 0.15

Remainder: Al

(Limits are in percent maximum unless stated otherwise).

Applications

Sealium® may be used wherever a stronger welded aluminium structure is desired, from hulls to superstructures. Marine structures benefit from the excellent corrosion resistance offered by Sealium®.

Smaller boats (< 50 m) benefit from improved scantlings, which translate into structural weight savings on patrol craft, increased strength on workboats or added interior space in luxury yachts. Larger vessels (> 50 m) profit from the increased strength and improved fatigue behavior of Sealium®. Cruise ship superstructures can be lightened further while improving stability and not compromising strength or corrosion resistance.

Advantages

15 % higher welded yield strength than standard 5083 alloy:

- Increased margin of safety from same scantlings.
- Significant weight savings from optimized scantlings.

Proven improved corrosion resistance.

Increased fatigue strength.

Same usage properties as 5083 alloy:

- Formability: same cutting, bending and shaping.
- Welding: no change in welding procedure, consumables or heat induced deformation.

Greater recycling value for the entire Sealium® welded assembly.

Thickness

Thickness range			
standard		on request	
mm	in.	mm	in.
th ≤ 50	th ≤ 1.97	50 < th ≤ 80	1.97 < th ≤ 3.15

Corrosion resistance

Sheets or plates made of Sealium® marine grade aluminium alloy offer a guaranty of intergranular and exfoliation corrosion resistance for severe marine applications as described in ASTM B928 (marine hull construction or marine applications where frequent or constant direct contact with sea water is expected). Accelerated tests and marine exposure (air and immersion) as well as experience have proven the long term corrosion resistance of Sealium®. Sealium® offers a better mechanical resistance on welded components than standard alloy 5083 with a good or better corrosion resistance.

Mechanical properties

Thickness Range (mm)	Rp _{0.2} (MPa)	Rm (MPa)	A %
3 ≤ th ≤ 50	220	305	10

Thickness Range (in.)	Rp _{0.2} (ksi)	Rm (ksi)	A %
0.125 ≤ th ≤ 2	32	44	10

Minimal mechanical properties as per Alcan specification IS 5423. As information, welded Sealium® shows a Rp_{0.2} minimal value of 145 MPa or 21 ksi to be compared to 125 MPa or 18 ksi for standard 5083 alloy. This value is considered by the main classification societies.

Bending properties

Sealium® sheets (th < 12.5 mm or 0.492 in.) are capable of being bent cold through an angle of 90 deg. around a pin having a radius equal to N times the thickness (th) of the sheet without cracking.

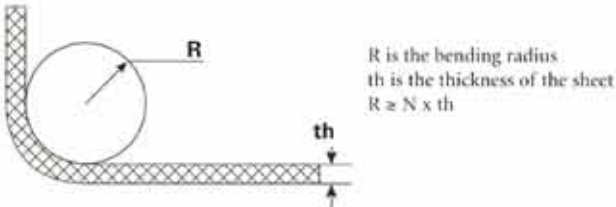

The certified minimum bending radius is given in the following table:

Thickness		Certified minimum bending radius
mm	in.	
2 < th ≤ 3	0.079 < th ≤ 0.118	R ≥ 2.0 x th
3 < th ≤ 6	0.118 < th ≤ 0.236	R ≥ 2.5 x th
6 < th ≤ 12.5	0.236 < th ≤ 0.492	R ≥ 4.0 x th

Type approval

Sealium® sheets/plates have been approved by the major classification societies :

- American Bureau of Shipping, USA (ABS)
- Bureau Veritas, France (BV)
- Det Norske Veritas, Norway (DNV)
- Germanischer Lloyd, Germany (GL)
- Lloyd's Register of Shipping, UK (LR)
- Nippon Kaiji Kyokai, Japan (Class NK)
- Registro Italiano Navale, Italy (RINA)

Standard manufacturing capabilities of Alcan Marine

Thickness		Max Width		Max Length	
mm	in.	mm	in.	mm	in.
4 ≤ th ≤ 4.5	0.157 ≤ th ≤ 0.177	2 260	89	15 000	590.55
4.5 < th ≤ 8	0.177 < th ≤ 0.315	2 400	94.5	15 000	590.55
8 < th ≤ 10	0.315 < th ≤ 0.394	2 400	94.5	12 500	492.13
10 < th ≤ 12.7	0.394 < th ≤ 0.5	2 400	94.5	10 350	407.48
12.7 < th ≤ 50	0.5 < th ≤ 1.97	3 050	120.1	*	*

* to be agreed on a case by case basis.

Contact us for non-standard dimensions.

Specific tolerances and properties are available upon request.

Reference specification

Alcan Marine specification: IS 5423.

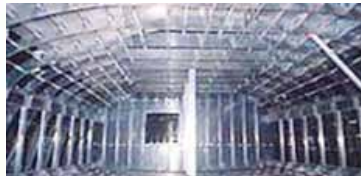

Hull under construction

SEALIUM®



The present document may under no circumstances be considered contractually binding. The information it contains is purely indicative and may under no circumstances be considered binding on Alcan or its subsidiaries, nor may it be used to contradict national or international regulations on the use, calculation or construction of aluminum alloy structures. It is the user's responsibility to check the accuracy of the information, refer to specialist works and contact experts of the Alcan group and those skilled in the field prior to use.



Sealium® Sheets, Plates and Extrusions, Marine Grade Aluminium Alloys from Ullrich Aluminium



FLAT BAR

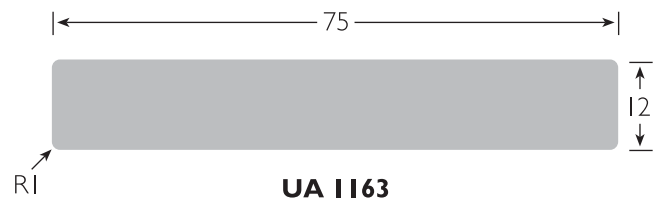
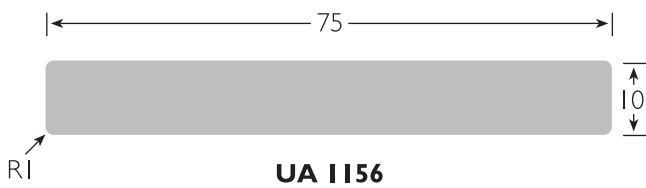
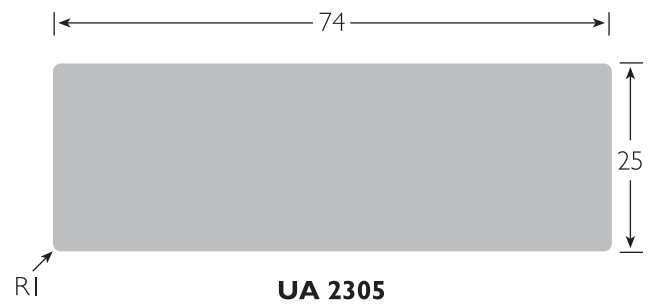
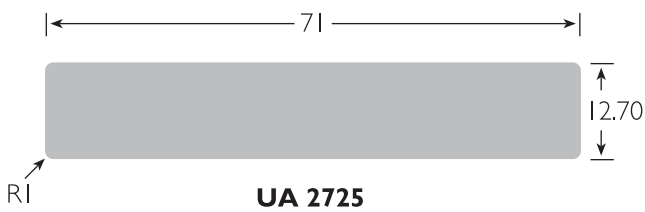
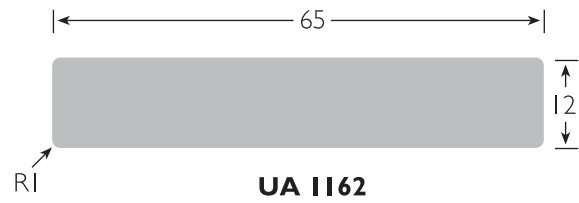
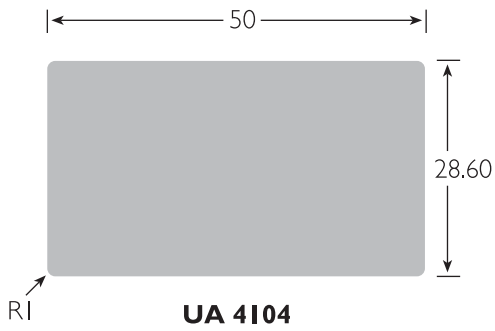
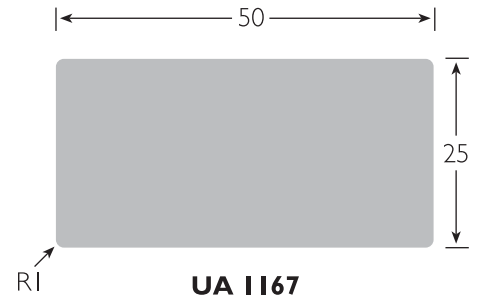
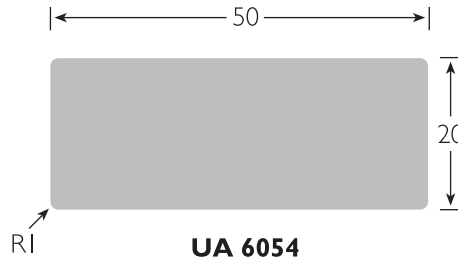
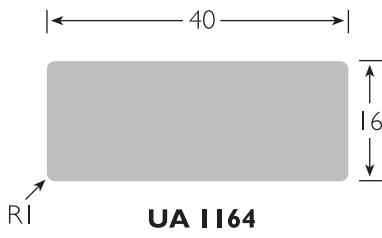
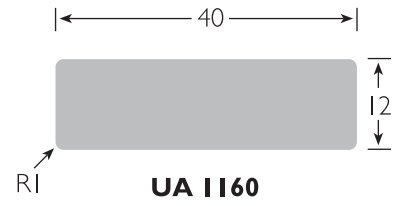
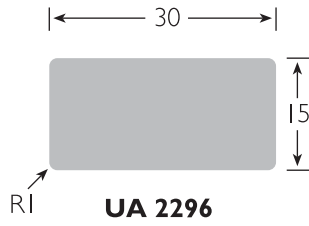
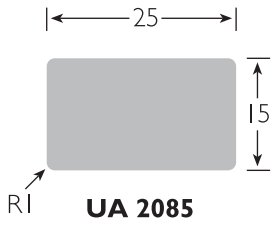

FLAT BAR

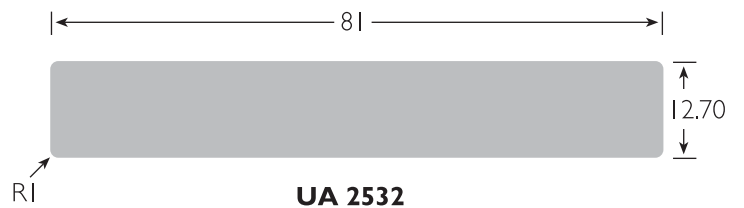
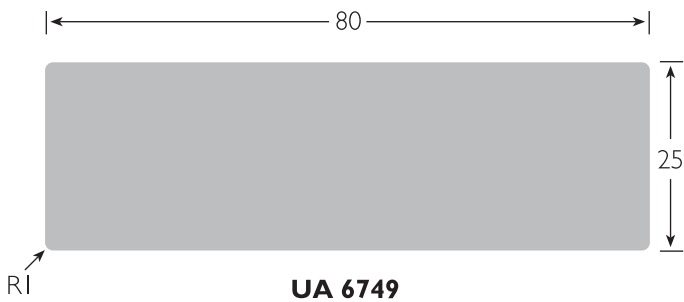
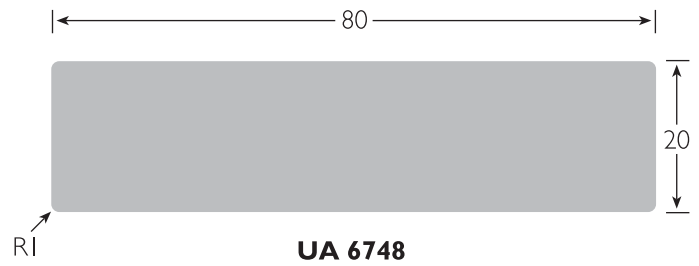
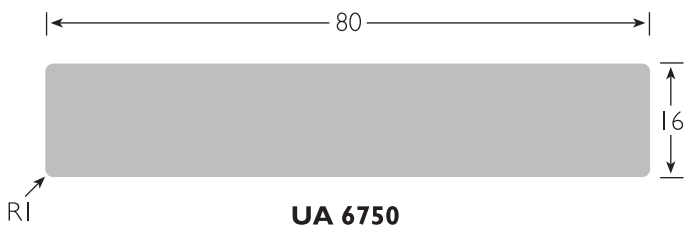
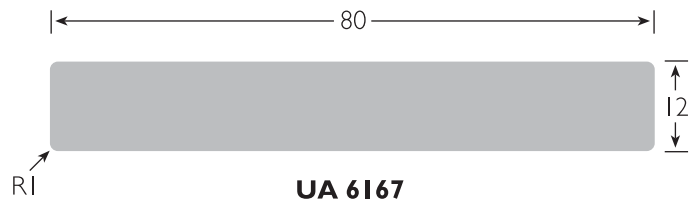
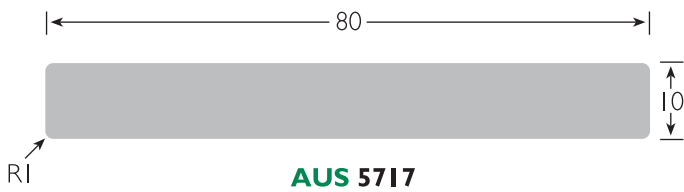
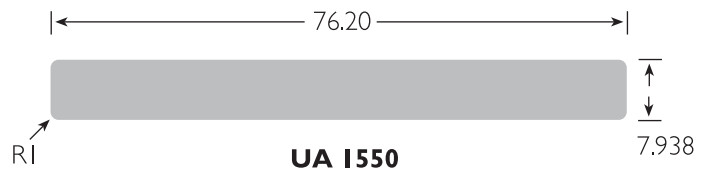
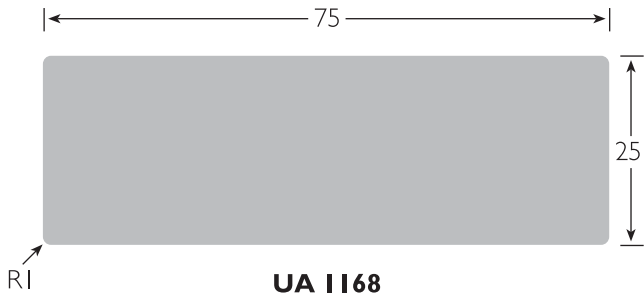
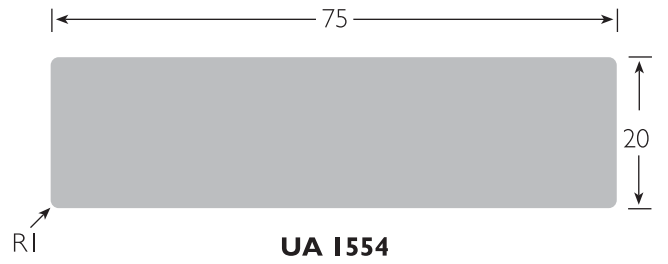
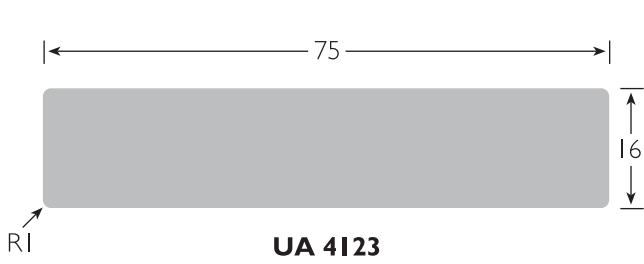

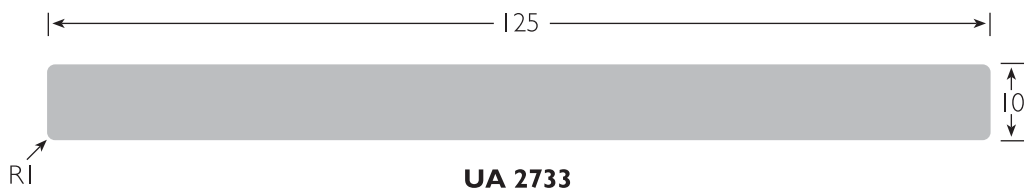
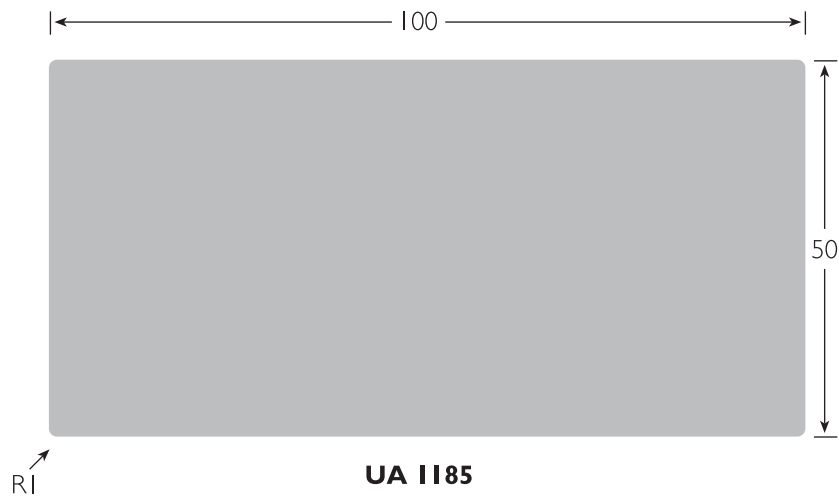
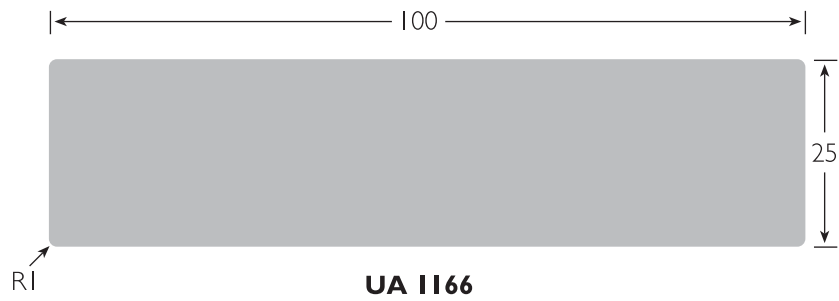
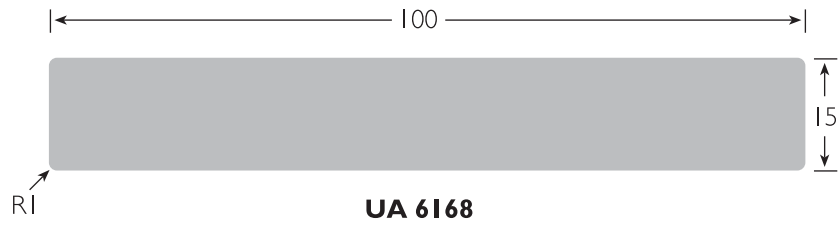
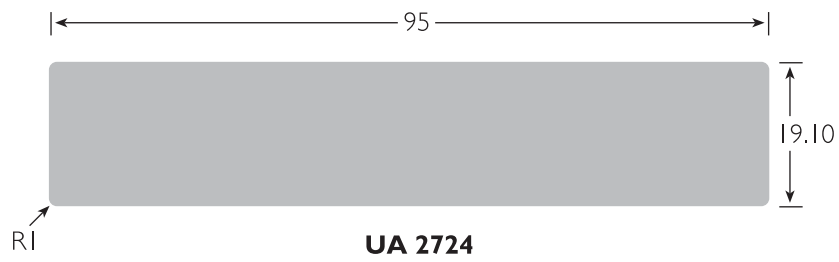

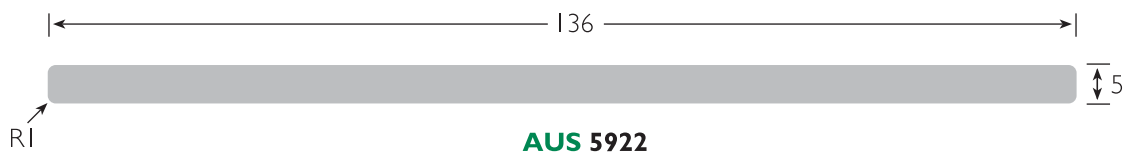
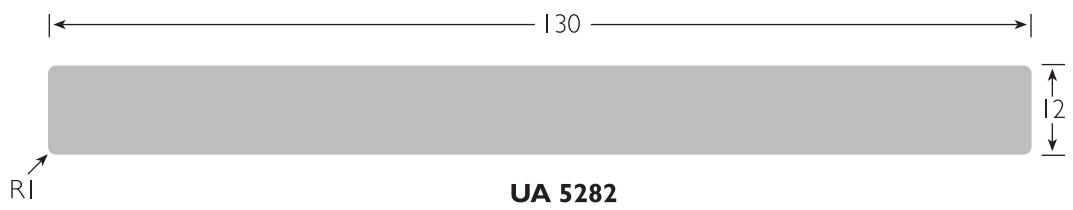
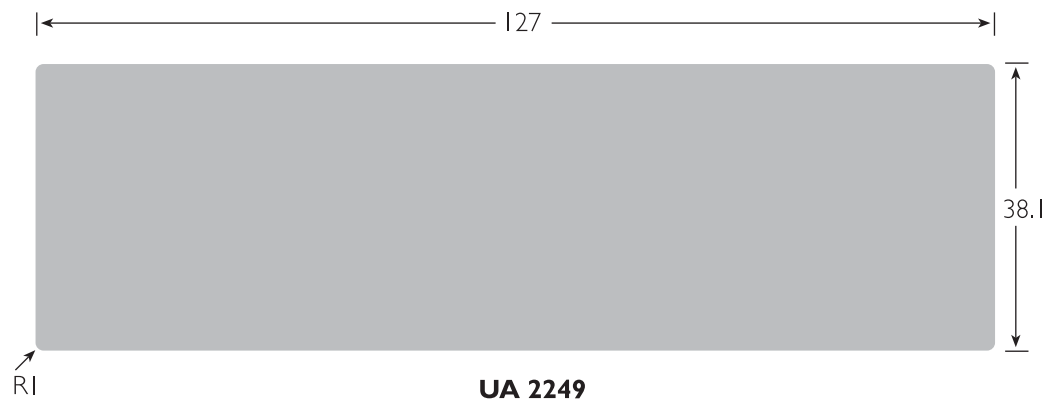
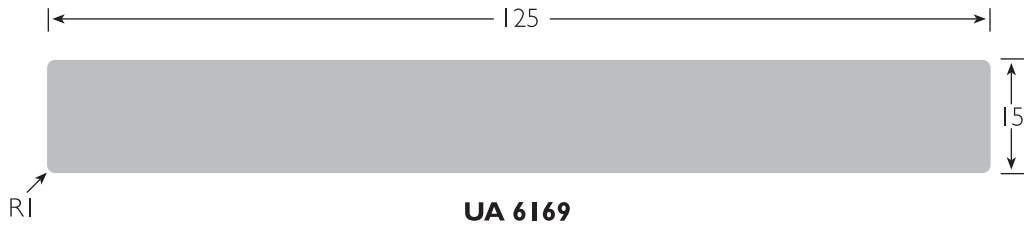
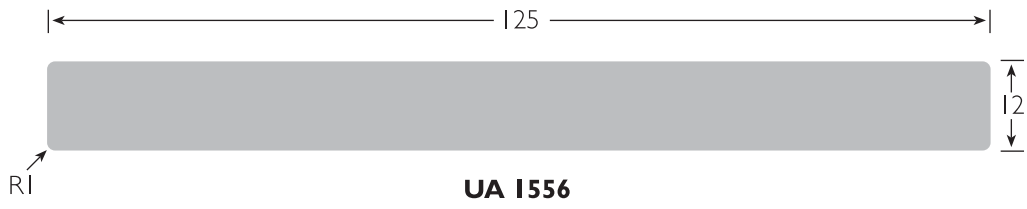

FLAT BAR

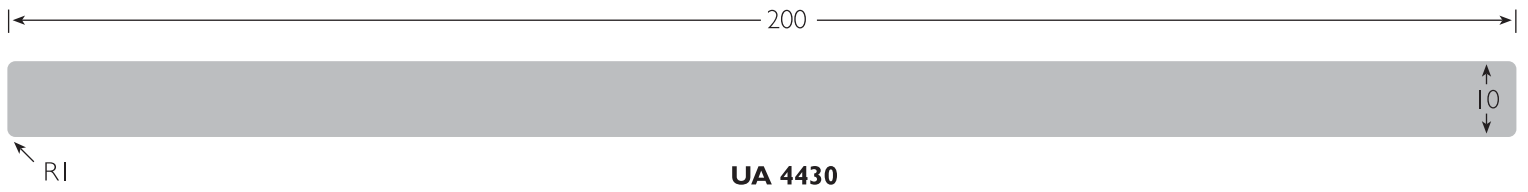
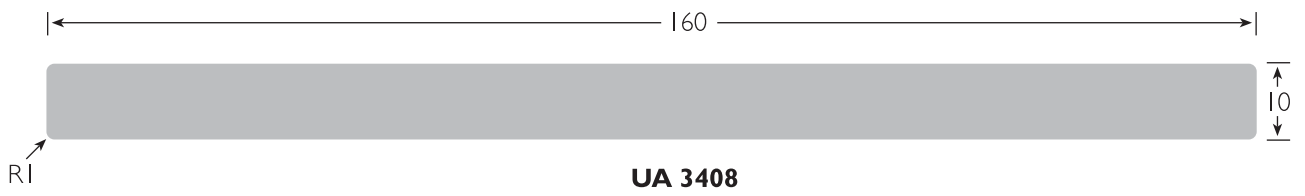
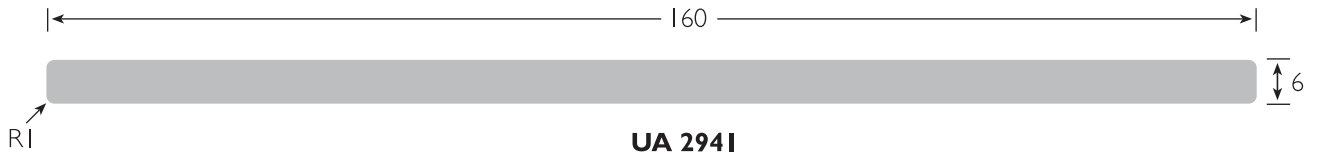
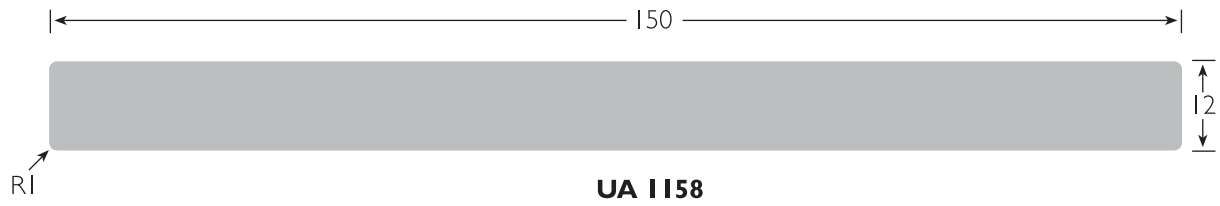

EXTRUDED ROUND TUBE

52

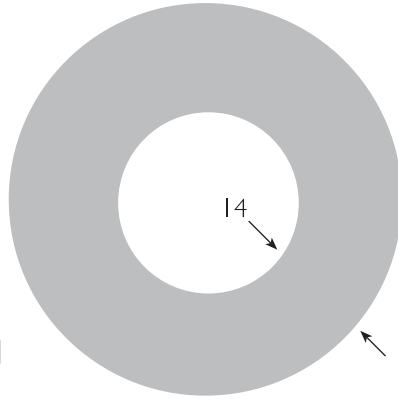

UA 4544

61.5

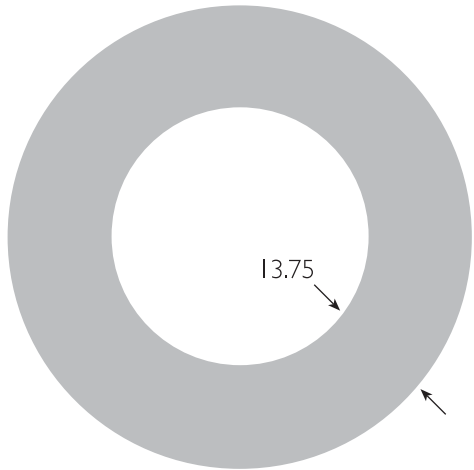

UA 4478

63.5

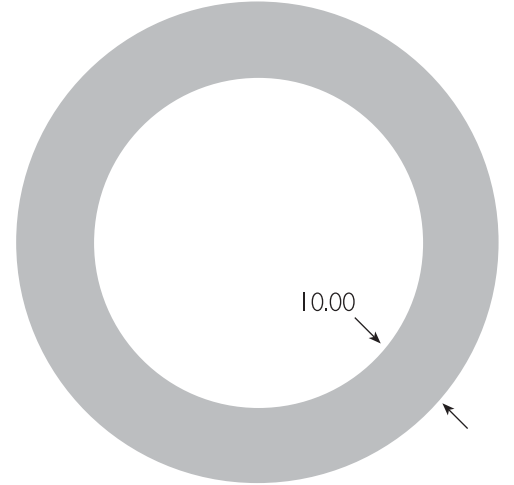

UA 5180

76.2

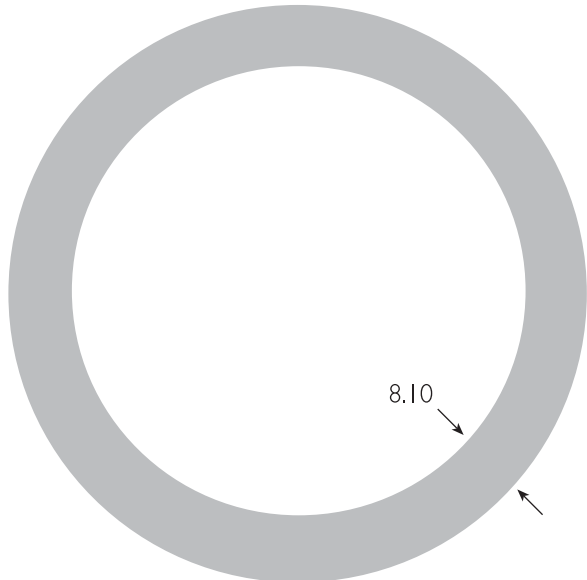

UA 4727

80

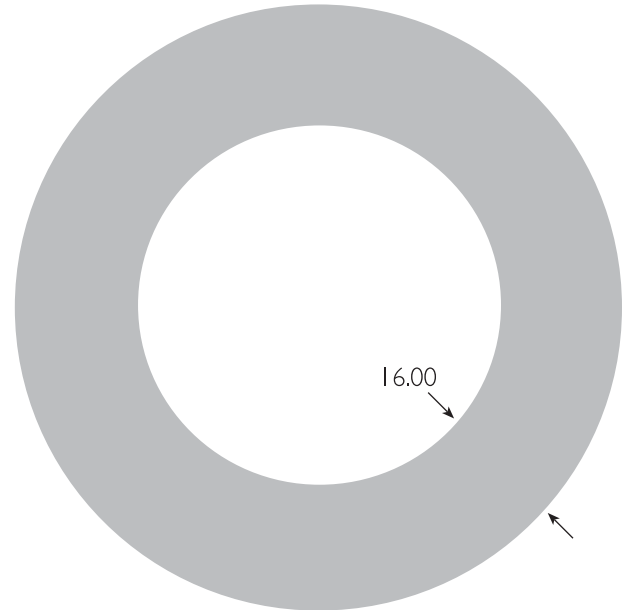

UA 6292



EXTRUDED ROUND TUBE

100

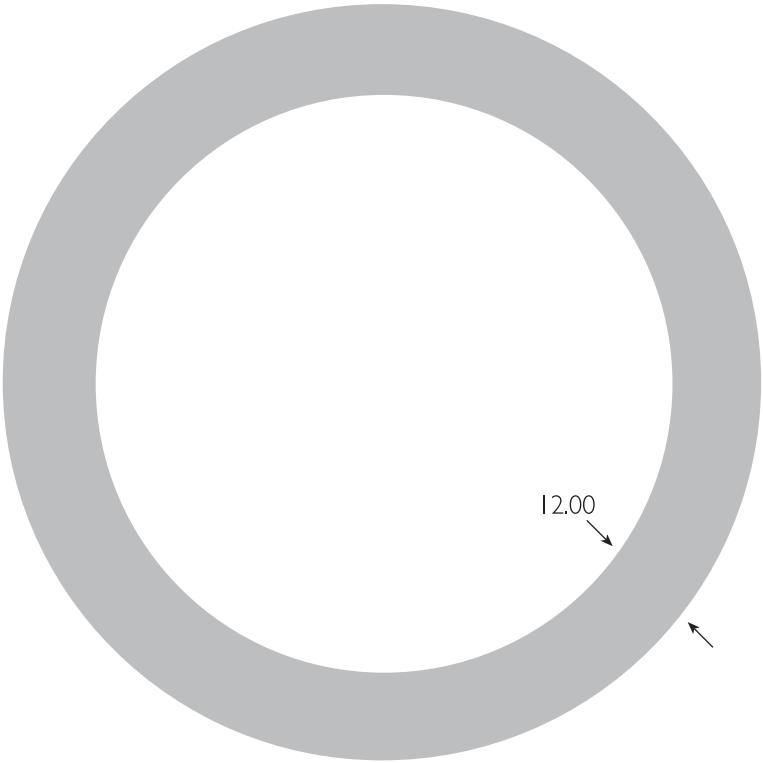

UA 5064

100

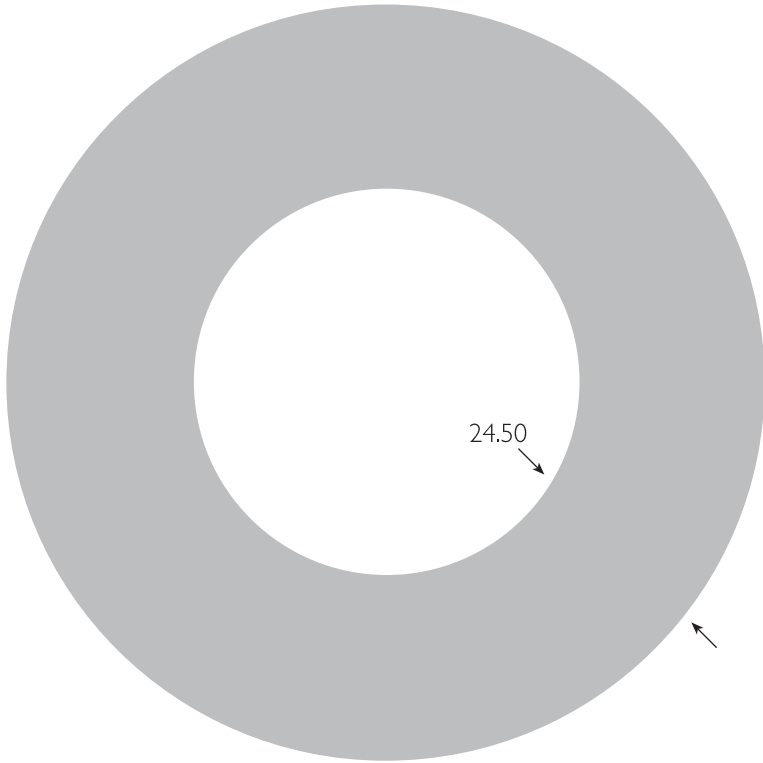

UA 2245

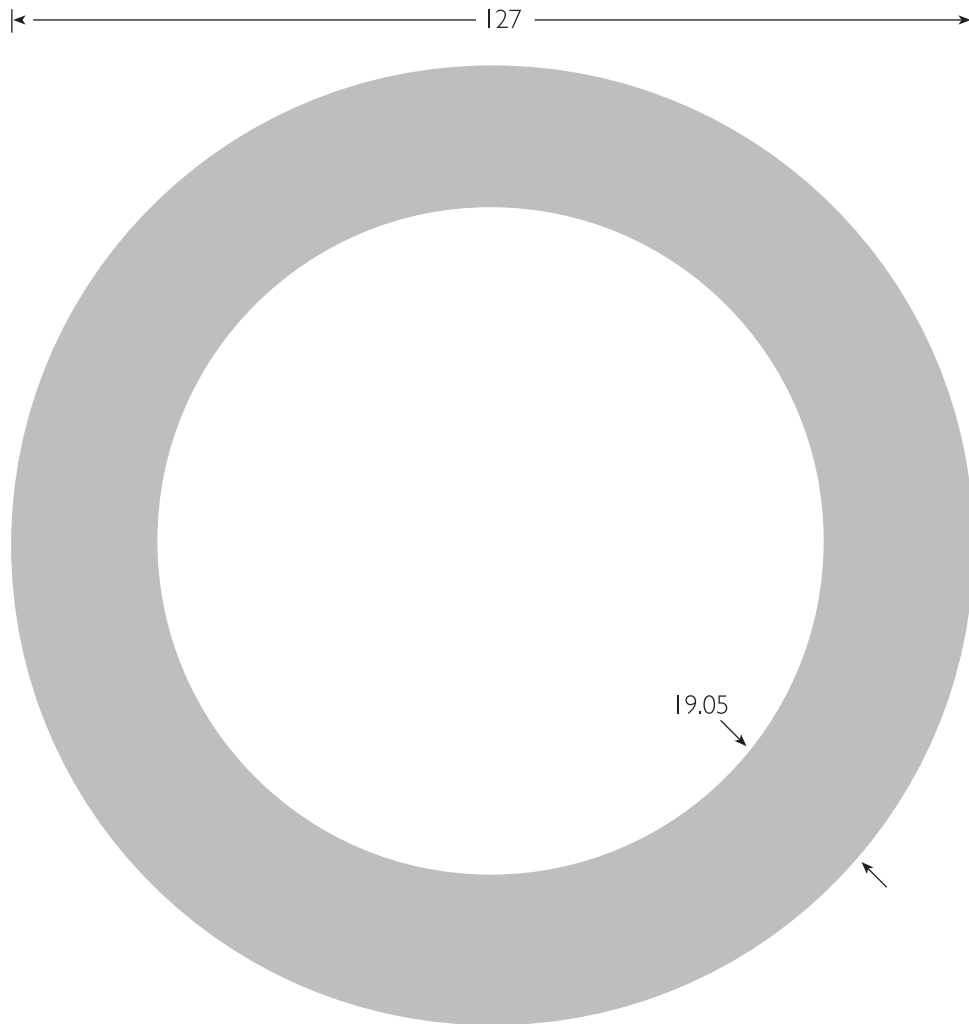

UA 5945

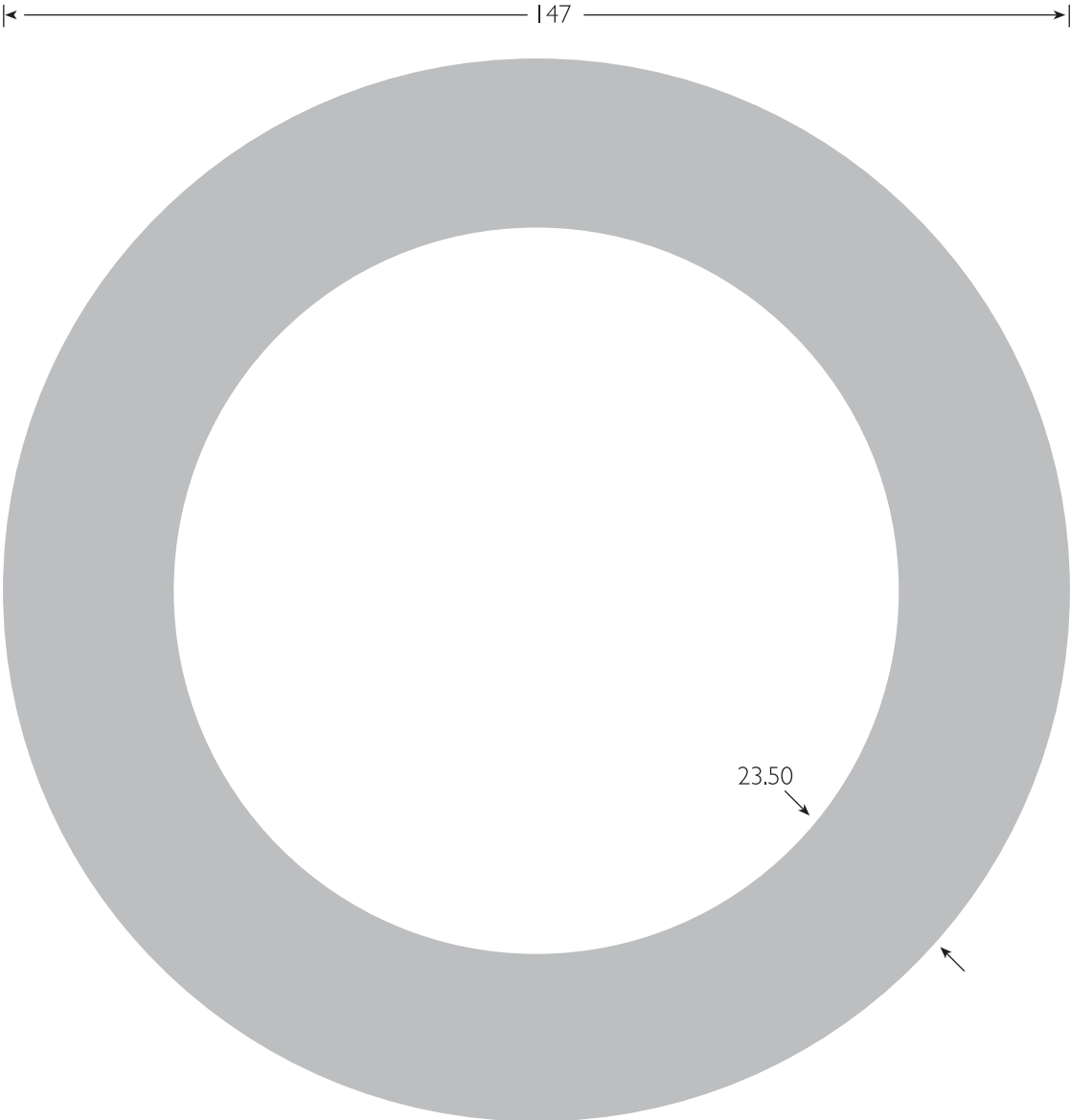

UA 5946

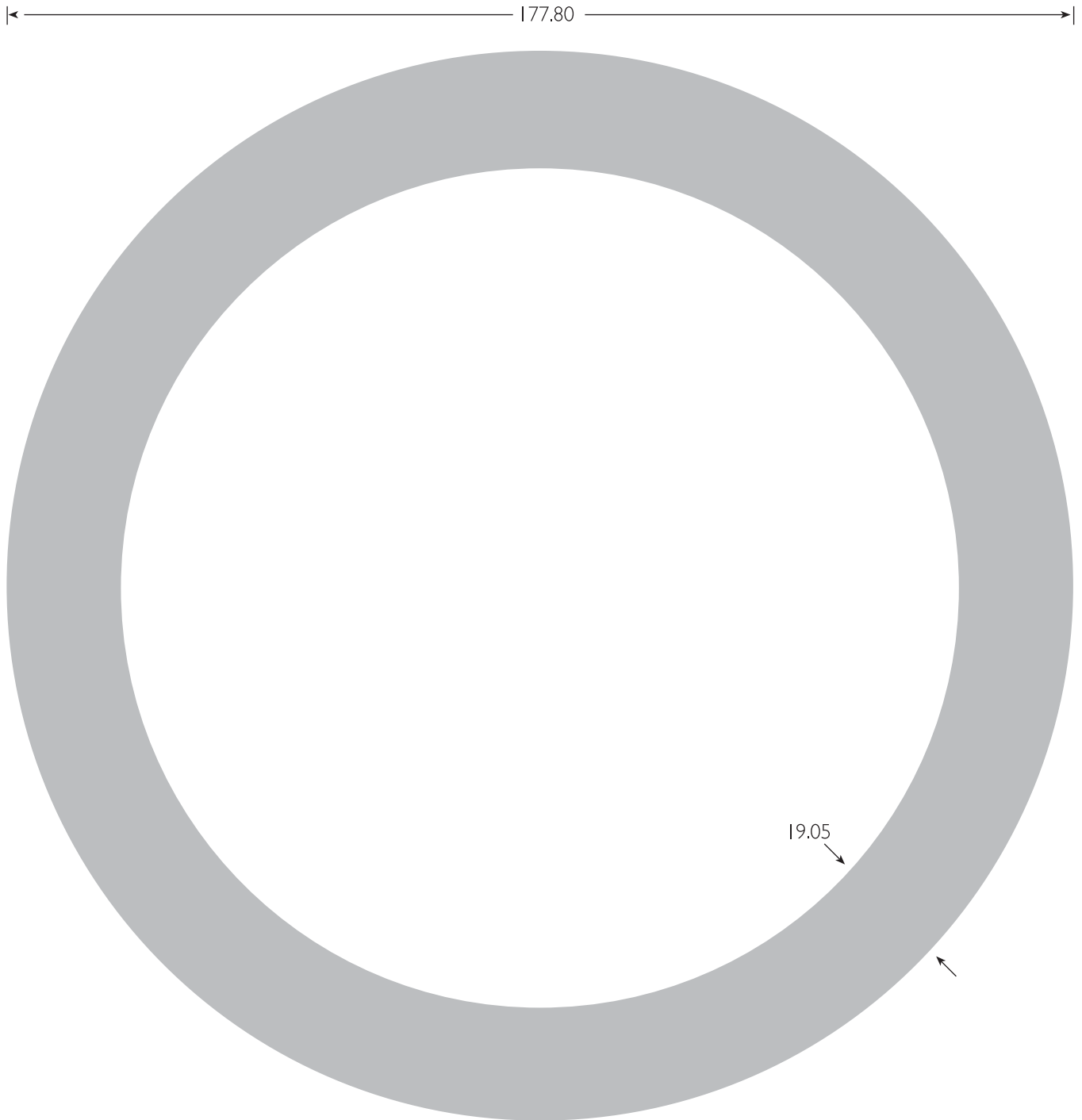

UA 5947

← 203.20 →

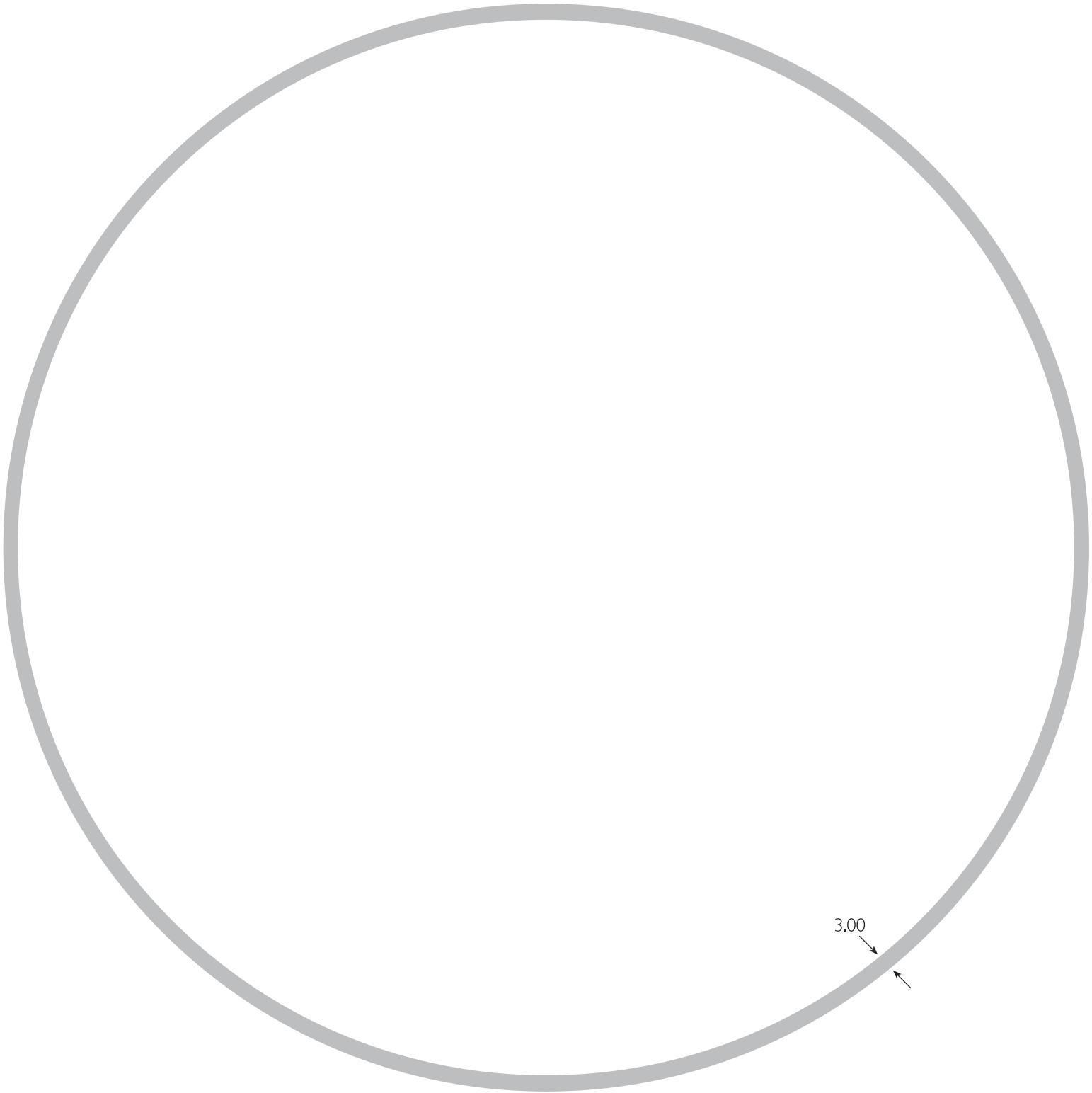

UA 6139

203.20

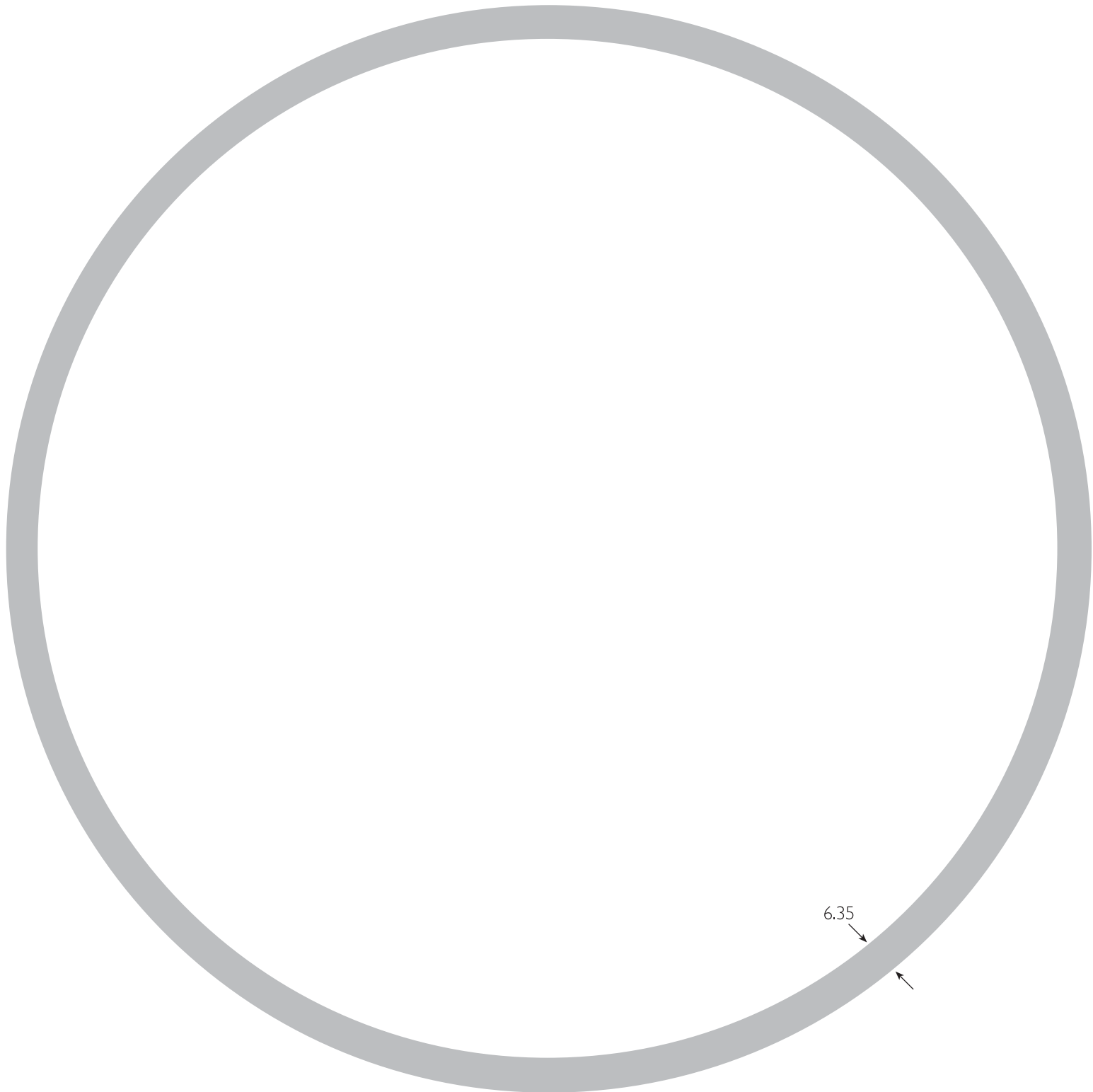

UA 3822



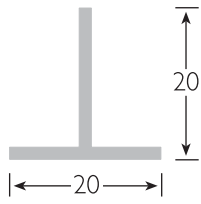

UA 1216

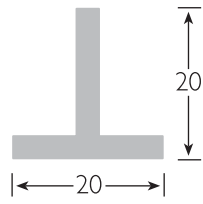

UA 1217

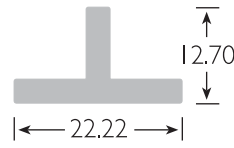

UA 1543

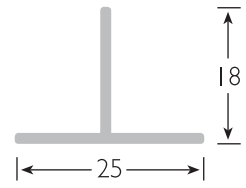

UA 1858

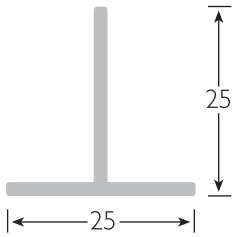

UA 1987

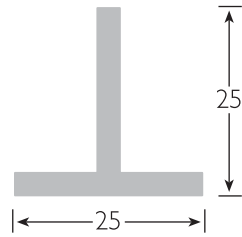

UA 1218

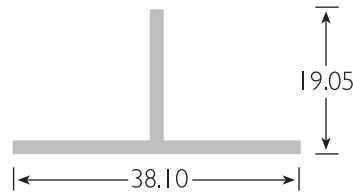

UA 1544

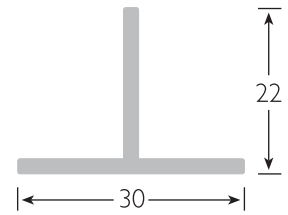

UA 2830

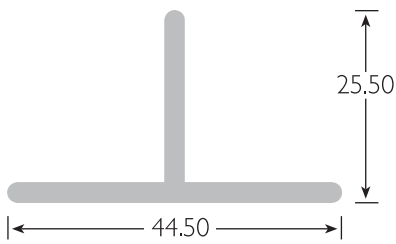

UA 1344

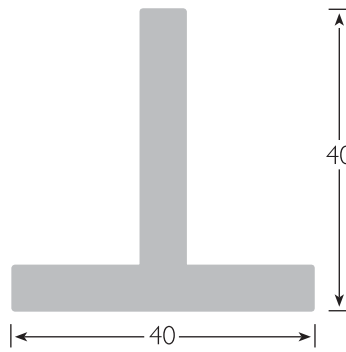

UA 3071

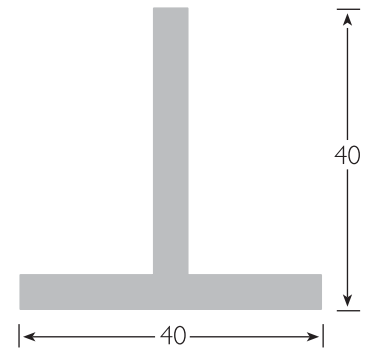

UA 1545

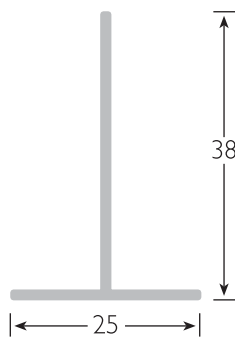

UA 1967

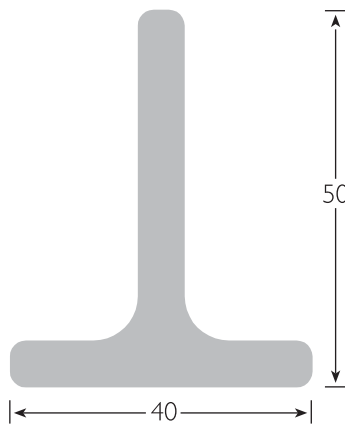

UA 3003

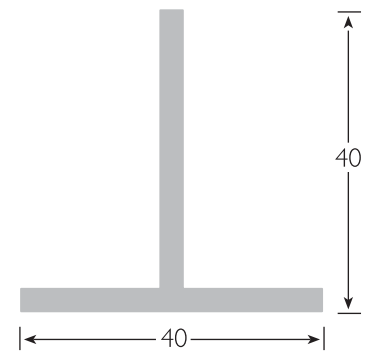

UA 1219

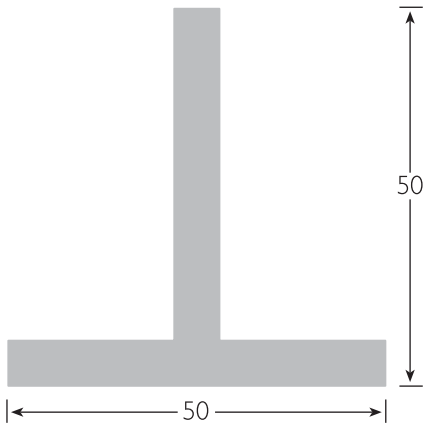

UA 1220

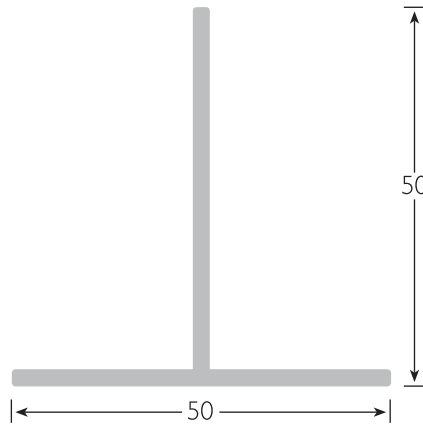

UA 3059

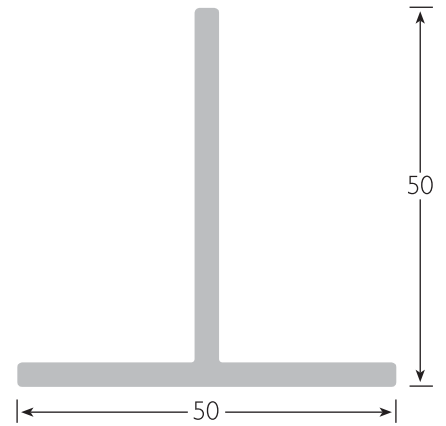

UA 1958

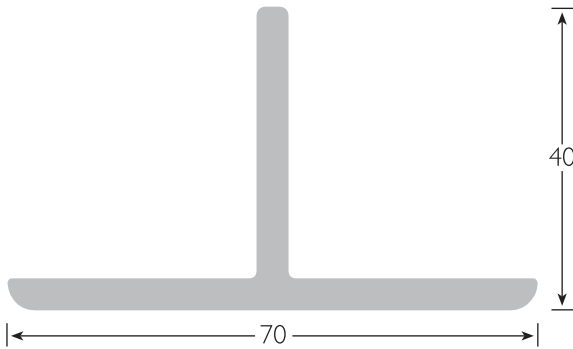

UA 2437

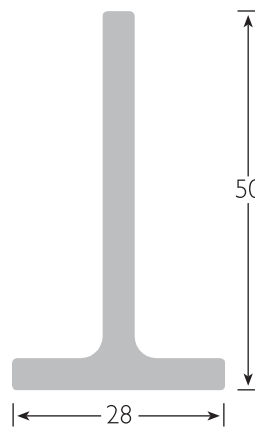

UA 4224

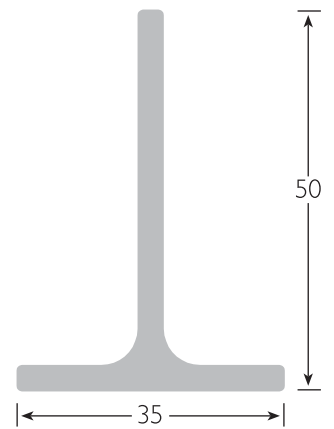

UA 5278

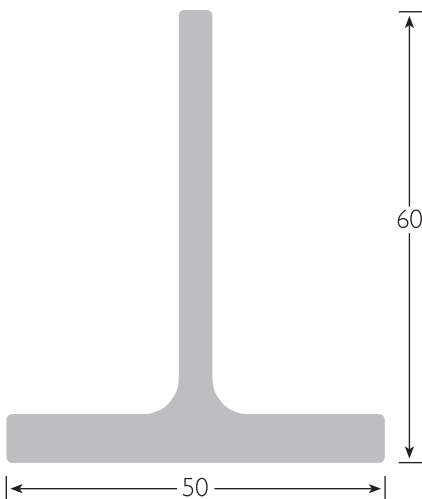

UA 5277

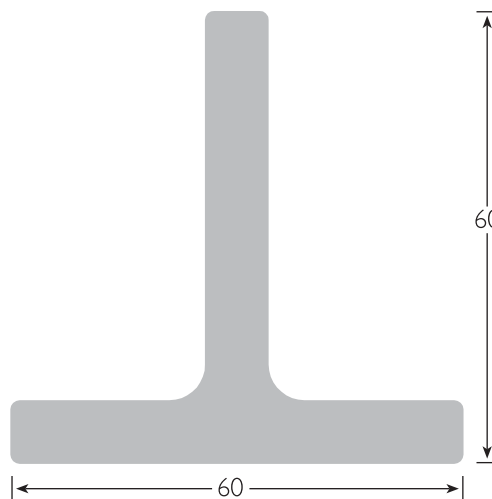

UA 6722

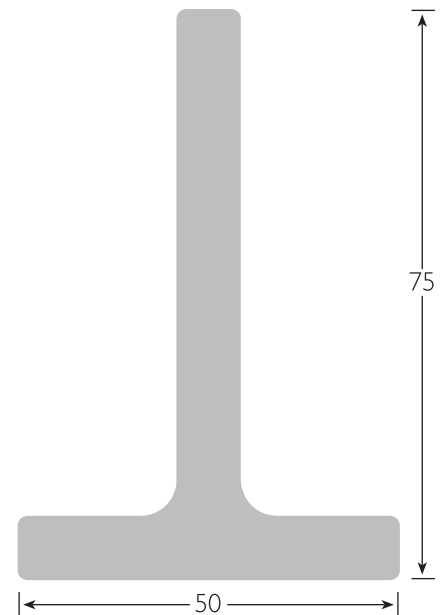

UA 6723

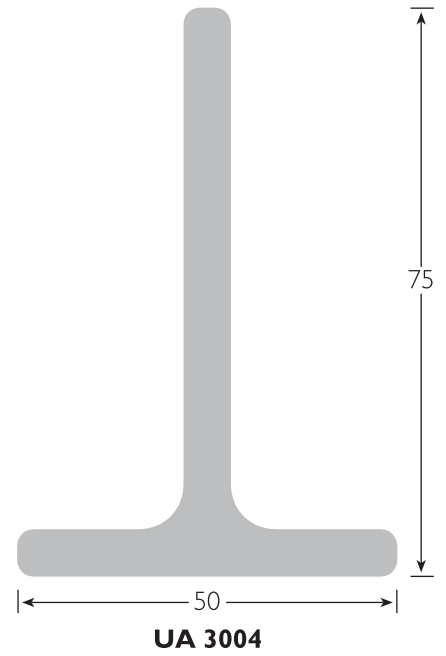
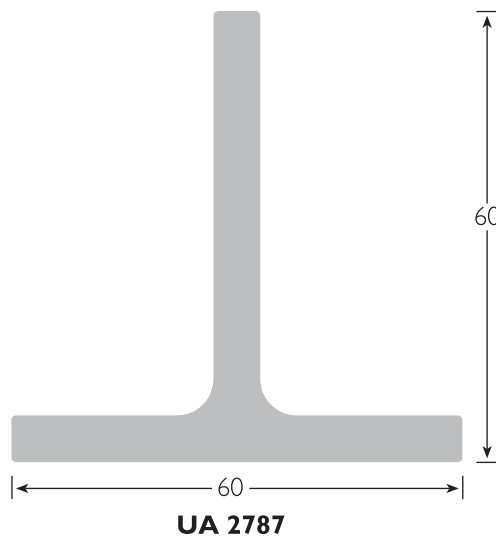
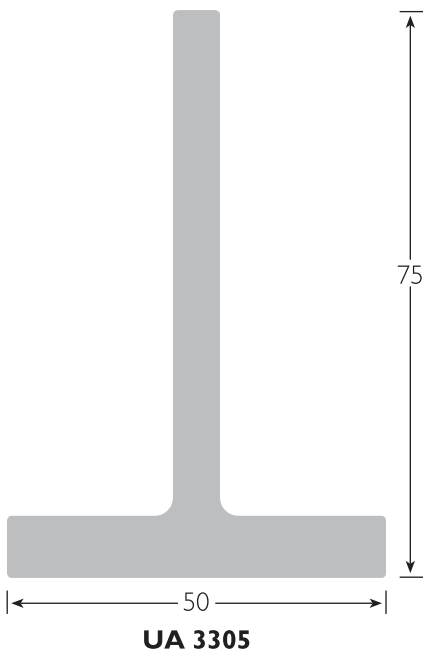
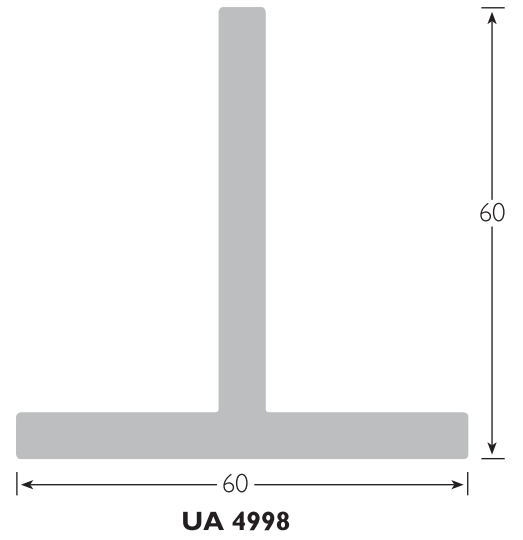
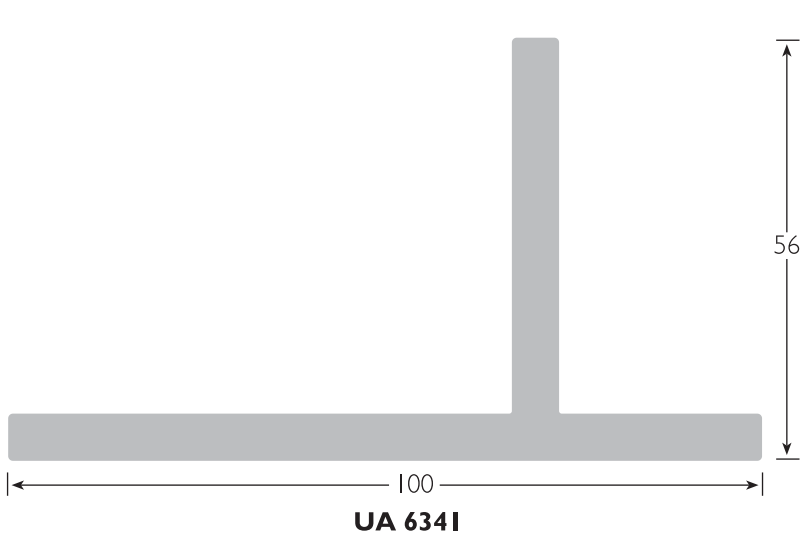

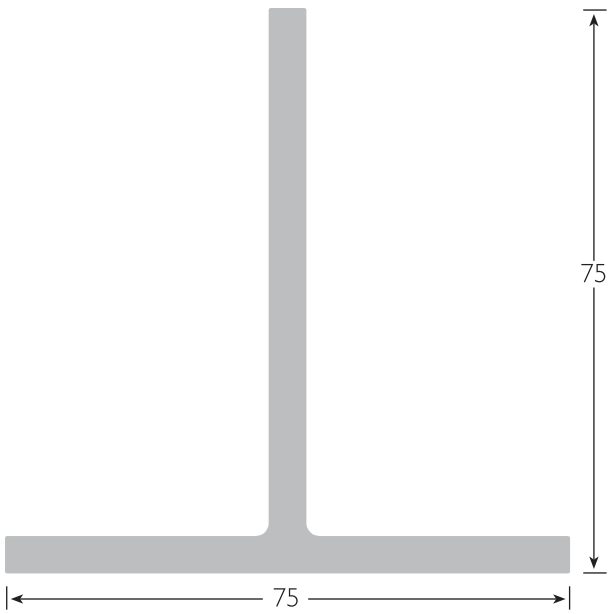

UA 1714

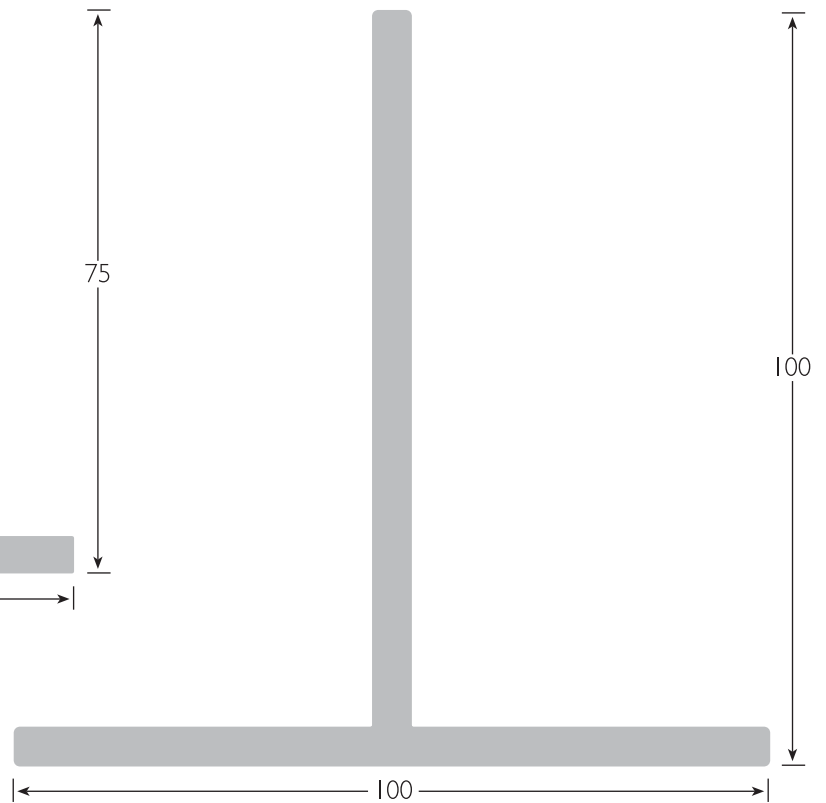

UA 4234

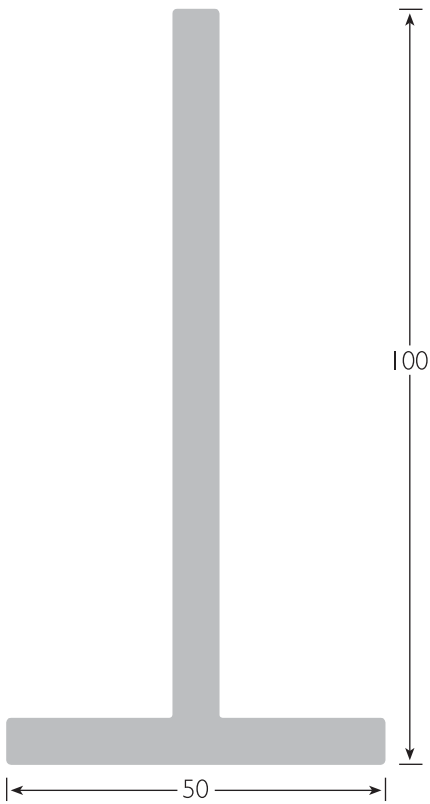

UA 4517

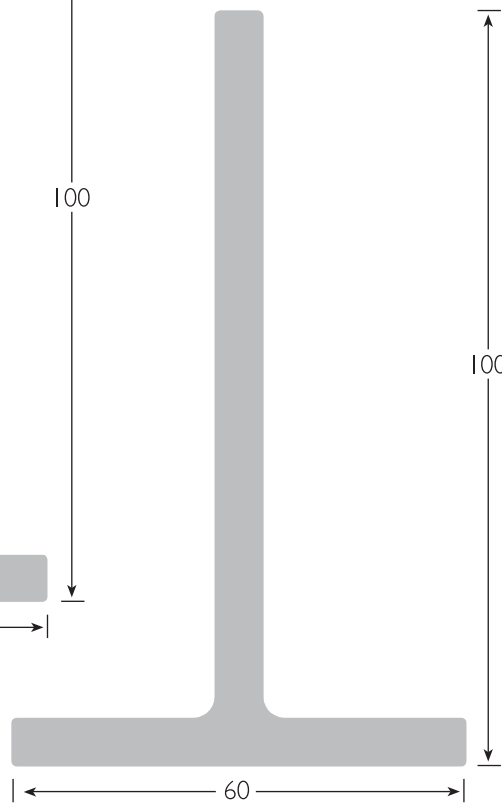

UA 6965

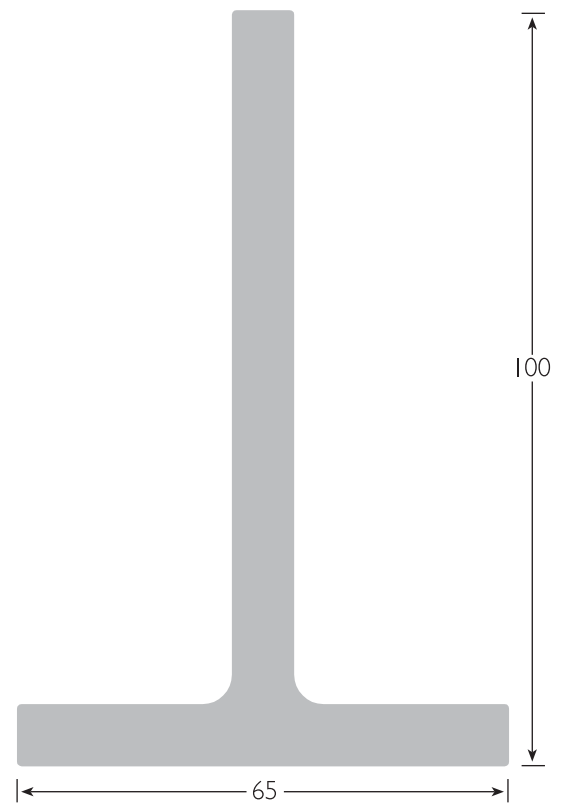

UA 5238



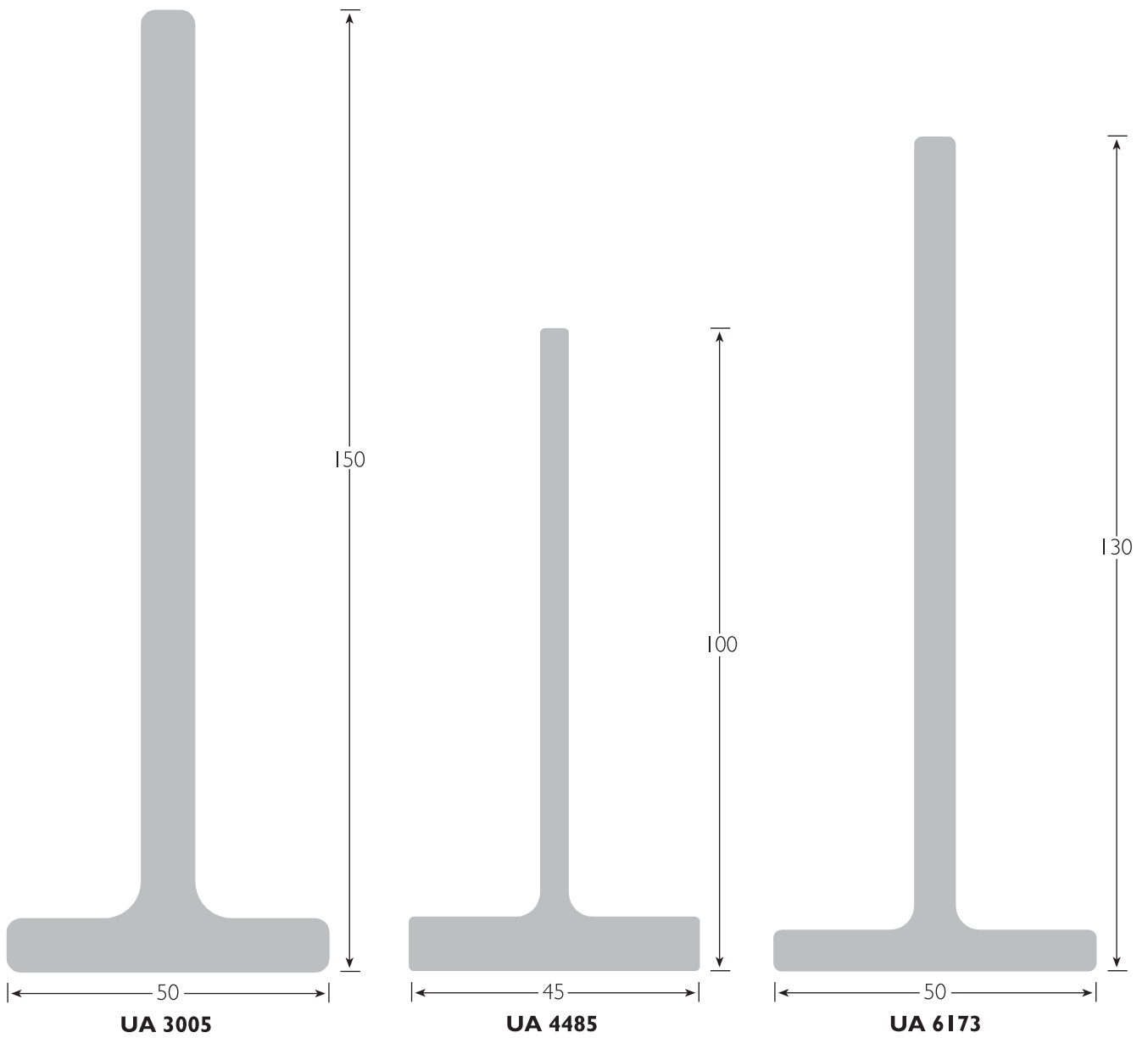

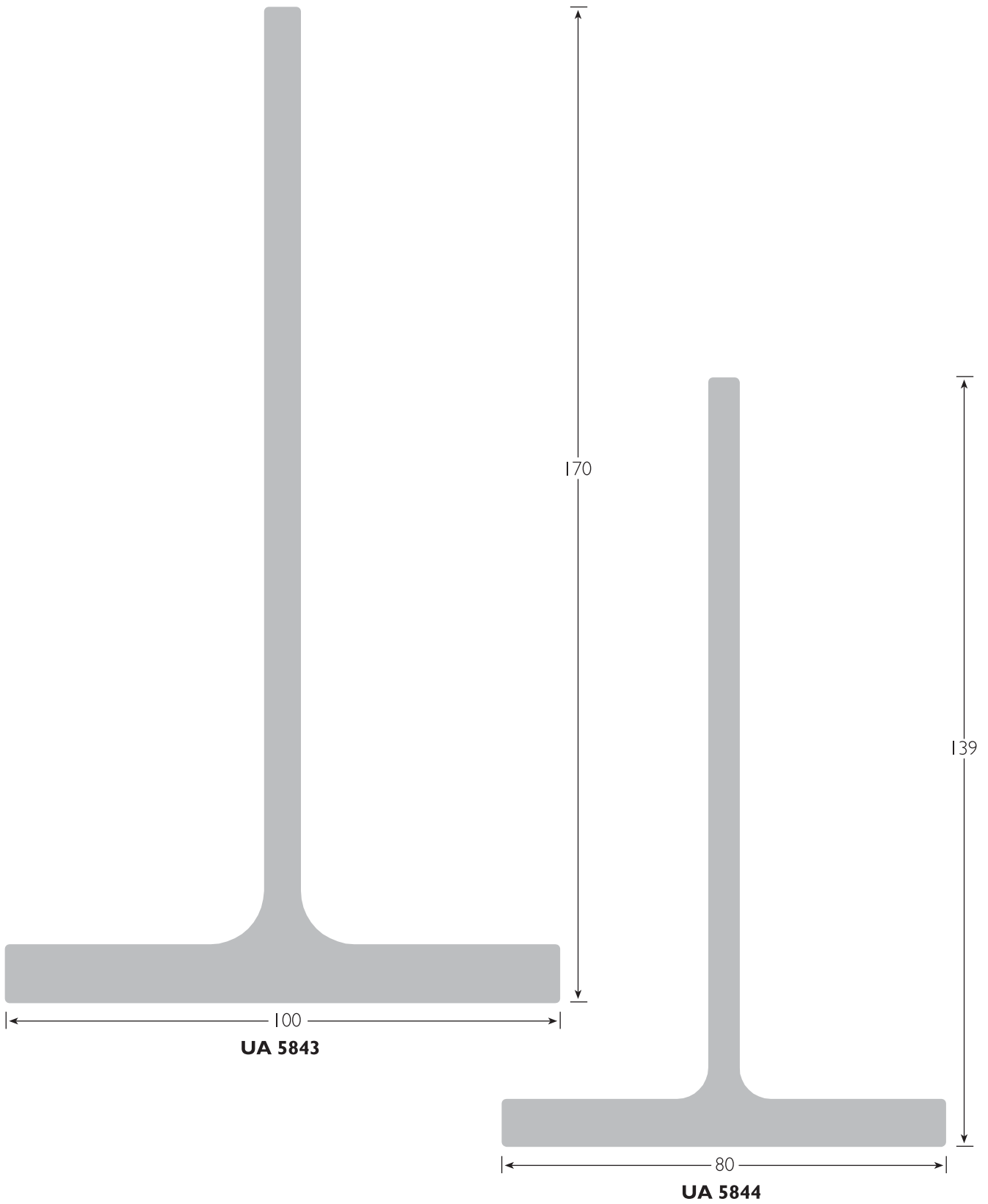

SEALIUM TEE

5UA 7069

TEE
kg/m 1.4327 P 214
OAD 60 x 50

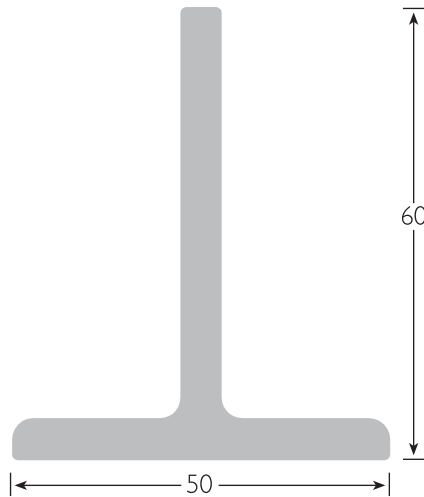

5UA 7069

5UA 7070

BULBED TEE
kg/m 1.447 P 214
OAD 70 x 40

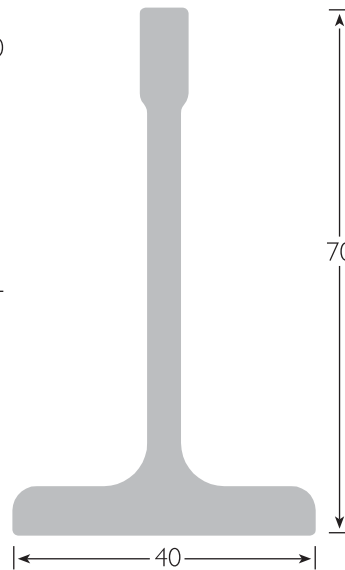

5UA 7070

5UA 7071

BULB TEE
kg/m 1.086 P 185
OAD 60 x 35

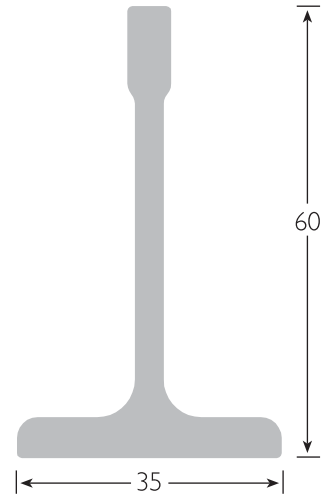

5UA 7071

BULBED FLAT

UA 2972

BULBED FLAT
kg/m 1.397 P 183
OAD 76.2 x 19



UA 2972

UA 5283

BULBED FLAT
kg/m 1.691 P 228
OAD 98.7 x 18.9



UA 5283

UA 1318

TOE RAIL
kg/m 0.220 P 81
OAD 20.6 x 19.6

UA 1318



UA 1335

UA 1335

TOE RAIL
kg/m 0.843 P 173
OAD 47 x 47

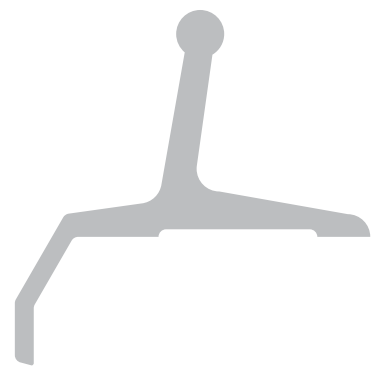

UA 1415

TOE RAIL Prepunched
kg/m 1.130 P 219
OAD 65 x 50.5

UA 1415



UA 1519

UA 1519

TOE RAIL Prepunched
kg/m 2.202 P 235
OAD 57.1 x 50.5

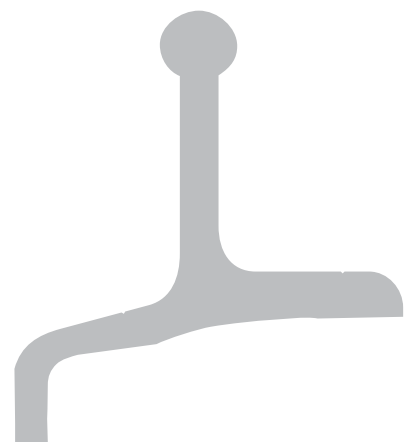

UA 1520

TOE RAIL Prepunched
kg/m 1.158 P 210
OAD 57.1 x 50.5

UA 1520

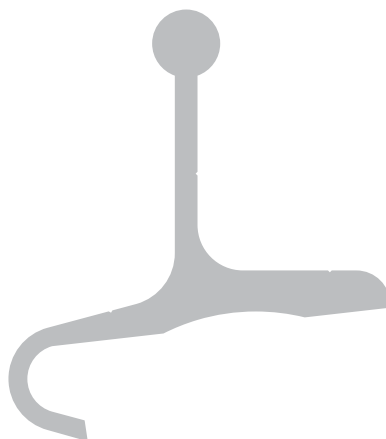

UA 2875

KEEL

kg/m 1.627 P 266

OAD 77.6 x 32.2

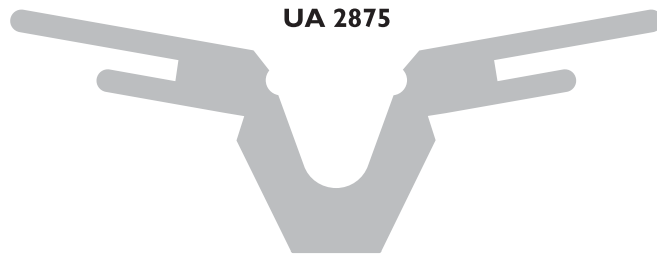

UA 3212

KEEL

kg/m 1.009 P 135

OAD 38.7 x 29.55



UA 3213

KEEL

kg/m 2.105 P 214

OAD 64.3 x 45



UA 3811

KEEL

kg/m 1.169 P 157

OAD 40 x 30



UA 1640

4mm GUNNEL
kg/m 0.861 P 167
OAD 38 x 32

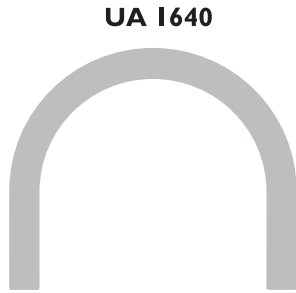

UA 3079



UA 2687

GUNNEL RAIL
kg/m 0.758 P 198
OAD 47 x 33

UA 2907

GUNNEL RAIL
kg/m 1.107 P 260
OAD 90.1 x 16

UA 3943



UA 5236

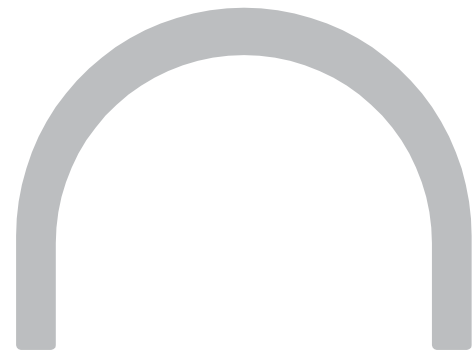

UA 3079

4-5-4mm GUNNEL
kg/m 1.110 P 194
OAD 50 x 35

UA 3147

GUNNEL RAIL
kg/m 0.831 P 263
OAD 65 x 40

UA 3747

HULL PLANING STRIP
kg/m 0.526 P 79
OAD 30 x 12

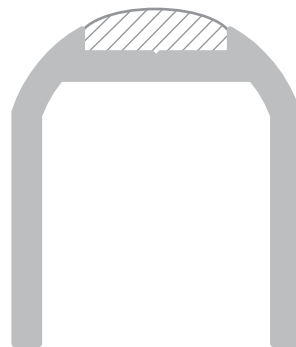

10UA 7072



UA 3857

GUNNEL RAIL
kg/m 0.987 P 221
OAD 43 x 33

UA 3943

5mm GUNNEL
kg/m 1.571 P 243
OAD 60 x 45

UA 2907

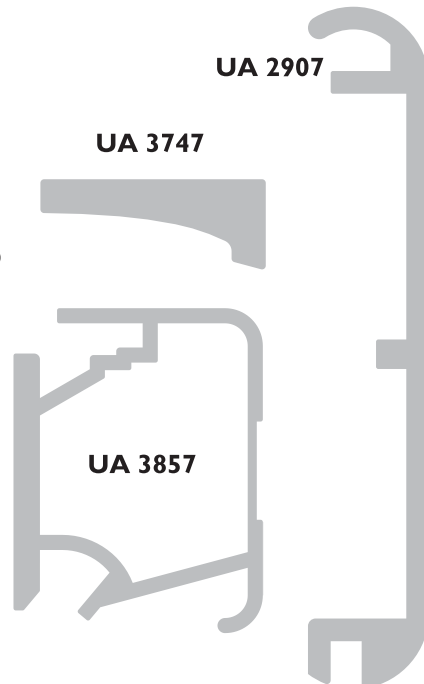

UA 4903

GUNNEL RAIL
kg/m 1.109 P 222
OAD 42.2 x 38
Takes 19mm Timber Fillet
(NOT AVAILABLE AT ULLRICH)

UA 3747



UA 3147

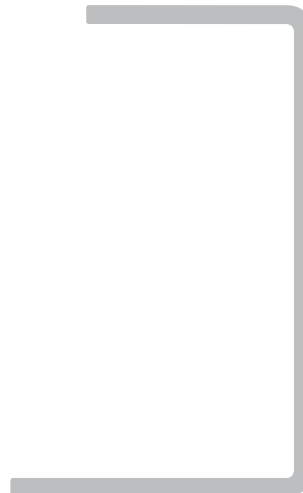

UA 2687



UA 5236

5-6-5mm GUNNEL
kg/m 1.706 P 240
OAD 60 x 45

UA 3857

10UA 7072

RUB RAIL
kg/m 2.322 P 298
OAD 55 x 75



UA 1417

RUB RAIL 31.6mm
kg/m 0.271 P 104
OAD 33 x 12 Infill 5206

UA 1427

RUB RAIL 32mm
kg/m 0.126 P 89
OAD 32 x 4.5 Infill 11 Serrated

UA 1428

RUB RAIL 17mm
kg/m 0.106 P 47
OAD 17 x 5 Infill 12

UA 1429

RUB RAIL 25mm
kg/m 0.169 P 67
OAD 25 x 5 Infill 12

UA 1430

RUB RAIL 31mm
kg/m 0.120 P 82
OAD 31 x 4 Infill 12

UA 1431

RUB RAIL 40mm
kg/m 0.291 P 131
OAD 40 x 9 Infills 111, 112

UA 1483

RUB RAIL 25.2mm
kg/m 0.220 P 76
OAD 27 x 7 Infill 12

UA 1605

RUB RAIL 13mm
kg/m 0.077 P 40
OAD 13 x 4.5 Infill 11 Serrated

UA 1606

RUB RAIL 11.4mm
kg/m 0.088 P 44
OAD 13 x 7 Infill 11 Serrated

ENDCAPS

Endcaps are available for:
UA 1431 Code BOAENDCAP/40
UA 1417 Code BOAHHENDCAPS

INFILLS SOLD SEPARATELY

UA 1605



UA 1428



UA 1429



UA 1430



UA 1427



UA 1431



UA 1606



UA 1483



UA 1417



UA 1426

HERZIM THRESHOLD 89.5mm
kg/m 0.822 P 215
OAD 89.5 x 9 Infill 12



UA 2359

UA 1875

BUFFER RAIL 30mm
kg/m 0.427 P 127
OAD 30 x 15 Infill 5205

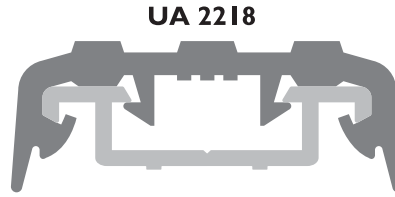

UA 2218

UA 2133

GUNNEL RUB RAIL
kg/m 0.752 P 180
OAD 33 x 27.5 Infill 5206

UA 1875

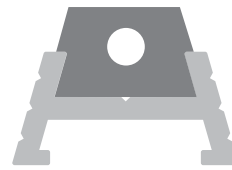

UA 2218

BUS RUB RAIL 58mm Cover
kg/m 0.402 P 144
OAD 43.5 x 11 Infill 5246

UA 2359

BUS RUB RAIL 50mm
kg/m 0.235 P 146
OAD 50 x 10 Infill 4870



UA 5118

UA 2583

RUB RAIL 59.3mm
kg/m 0.398 P 172
OAD 59.3 x 10.65 Infill 37

UA 2584

RUB RAIL 97.8mm
kg/m 0.615 P 276
OAD 97.8 x 9.9 Infill 111

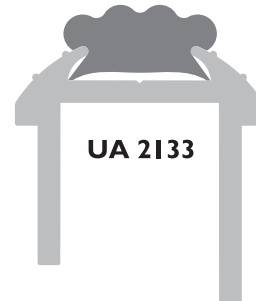

UA 2133

UA 5118

BOAT RUB RAIL 50mm
kg/m 0.696 P 172
OAD 50 x 23.85 Infill 5206

ENDCAPS

Endcaps are available for:
UA 2218 Code TRABUSENDCAP



UA 1426

INFILLS SOLD SEPARATELY

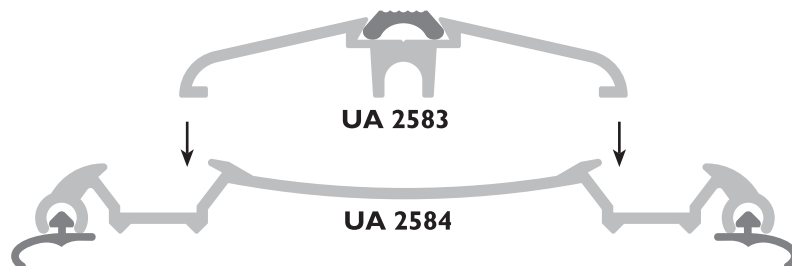

UA 2583

UA 2584



UA 1423

SAIL TRACK
kg/m 0.712 P 184
OAD 52 x 21



UA 1425

UA 1424

SAIL TRACK
kg/m 0.478 P 124
OAD 32 x 12



UA 1424

UA 1425

SAIL TRACK
kg/m 0.213 P 85
OAD 22 x 8

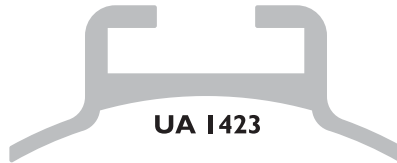

UA 1423

UA 7177

LIPPED CHANNEL
kg/m 1.717 P 188
OAD 50 x 12



UA 7177

UA 1416

PERSPEX JOINTER
kg/m 0.119 P 50
OAD 16 x 9

UA 1418

PERSPEX UPRIGHT
kg/m 0.434 P 129
OAD 25.5 x 18

UA 1419

5mm PERSPEX CAP
kg/m 0.538 P 118
OAD 25.5 x 14

UA 1420

5mm PERSPEX PILLAR CAP
kg/m 0.564 P 132
OAD 25.5 x 14

UA 1421

5mm PERSPEX CAP
kg/m 0.393 P 99
OAD 22 x 12

UA 1422

5mm FIBREGLASS CAP
kg/m 0.133 P 70
OAD 12 x 9

UA 1579

5mm PERSPEX SILL
kg/m 0.209 P 105
OAD 30 x 12

UA 2785

5.4mm PERSPEX CAP
kg/m 0.372 P 99
OAD 22 x 12

UA 5237

5mm PERSPEX CAP
kg/m 0.175 P 67
OAD 12.7 x 9.4



UA 1422



UA 1421



UA 1579



UA 5237

UA 1420



UA 1416



UA 1418

UA 1419



UA 2785



UA 1406

DBL SIDED AWNING RAIL
kg/m 0.335 P 111
OAD 32 x 13.7

UA 3418

SAIL TRACK
kg/m 0.458 P 130
OAD 31 x 17.5

UA 6553

FLANGED AWNING RAIL
kg/m 0.496 P 163
OAD 64.8 x 15.95

UA 3418



UA 1406



UA 6553



UA 2637

HULL JOINTER
kg/m 1.554 P 407
OAD 119.49 x 56.09

UA 3747

HULL PLANING STRIP
kg/m 0.526 P 79
OAD 30 x 12

UA 5179

HATCH SECTION
kg/m 1.368 P 245
OAD 63 x 45

UA 5889

DECK CAPPING
kg/m 2.926 P 347
OAD 90 x 54

UA 6770

HATCH SECTION
kg/m 2.587 P 246
OAD 52 x 50

UA 6771

HATCH SECTION
kg/m 3.088 P 366
OAD 81 x 73

UA 5179



UA 5889



UA 3747



UA 6770



UA 6771



UA 2637

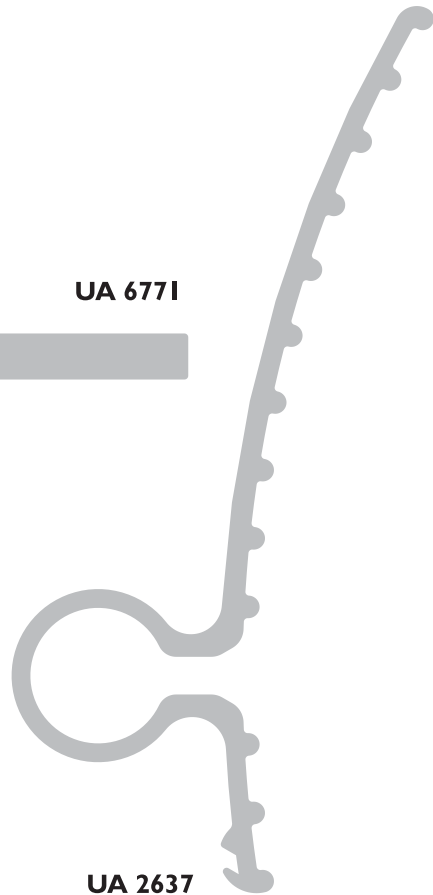

UA 2637

HULL JOINTER
kg/m 1.554 P 407
OAD 119.49 x 56.09

UA 3747

HULL PLANING STRIP
kg/m 0.526 P 79
OAD 30 x 12

UA 5179

HATCH SECTION
kg/m 1.368 P 245
OAD 63 x 45

UA 5889

DECK CAPPING
kg/m 2.926 P 347
OAD 90 x 54

UA 6770

HATCH SECTION
kg/m 2.587 P 246
OAD 52 x 50

UA 6771

HATCH SECTION
kg/m 3.088 P 366
OAD 81 x 73

UA 5179



UA 5889



UA 3747



UA 6770



UA 6771



UA 2637

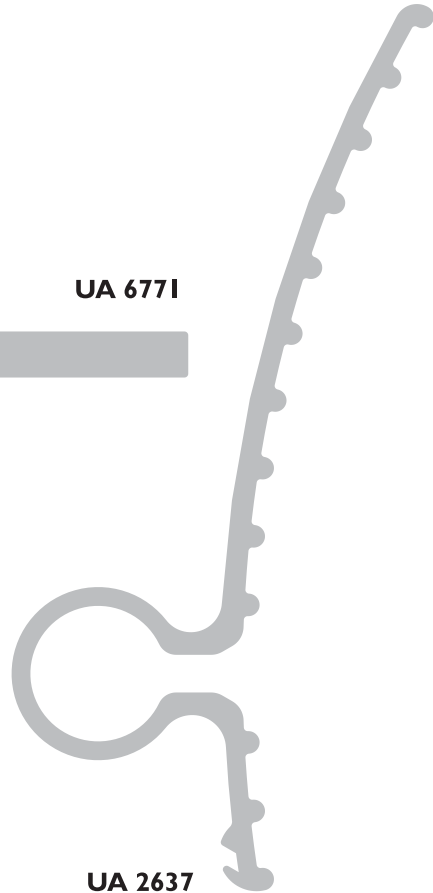

UC 1913
FLAT HINGE



UC 1915
CANOPY HINGE

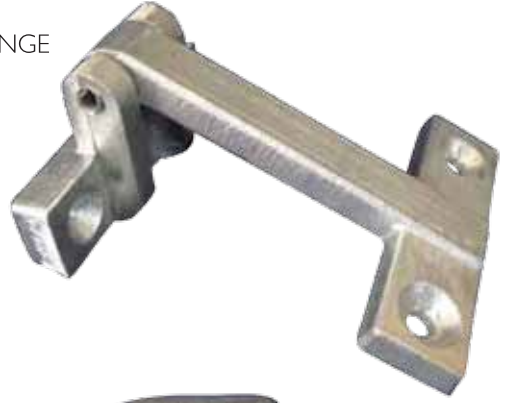

UC 1912
OFFSET HINGE



UC 1916
ROPE HOOK
Used on boats
and trailers
(not certified)



UC 1917
ROWLOCKS
- BLOCKS
Fit on dinghies
for oars



UC 1918
BOW RAIL
END CAP
For rails
around boat
windscreens



UC 1934
BOAT HOOK
For retrieving
ropes on boats



UC 1924
BOLLARDS
Used on boats



UC 1996
DINGHY BOW CAP



UC 1993
CAST BOAT CORNER



ANODES5.0KG

ALLOY - 290 x 130 x 60mm

ANODES12.5KGZ

ZINC - 290 x 130 x 60mm



ANODES3.0KG

ALLOY - 305 x 130 x 40mm

ANODES7.5KGZ

ZINC - 305 x 130 x 40mm



ANODES12.0KG

ALLOY - 600 x 145 x 50mm

ANODES30KGZ

ZINC - 600 x 145 x 50mm



ANODES8.0KG

ALLOY - 600 x 135 x 35mm

ANODES20.0KGZ

ZINC - 600 x 135 x 35mm



ANODEI6RODZ

ZINC - 16mm diam. rod 400mm long



ANODEFS

ALLOY - Water Tank Anode 950 x 26mm diam.

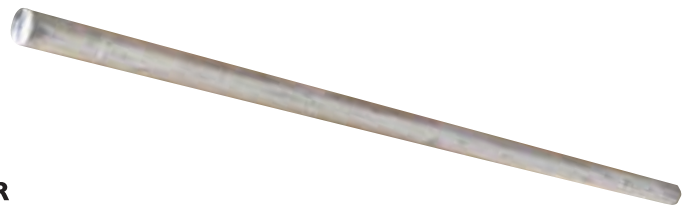

ANODEBAR

ALLOY - 40 x 30 x 20mm

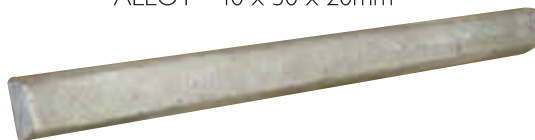

ANODES1.5KG

ALLOY - 110 x 145 x 40mm

ANODES3.5KGZ

ZINC - 110 x 145 x 40mm



ANODES1.0KG

ALLOY - Teardrop

ANODES2.5KGZ

ZINC - Teardrop



Ullrich Aluminium supplies the best quality aluminium welding wire from Europe. Swiss made precision, ingenuity and quality control achieve a reputation for technical excellence. Available nationwide.

ULLTRAWELD



ALUMINIUM WELDING WIRE - RODS MANUFACTURED IN SWITZERLAND



- MIG - TIG
- 5356
- 5183
- 4043
- D300 SPOOLS - 7 kg
- DI00 SPOOLS - 0.5 kg
- RODS - 5 kg

ISO 9001
BVQI
LLOYDS

MIG WIRE	CODE		SPOOL WEIGHT	Diameter
	5356	X	7 kg spools	1.0 and 1.2
	5183	X	7 kg spools	1.2
	4043	X	7 kg spools	1.2
MIG Wire	5356	X	0.5 kg spools	0.8, 0.9, 1.0 and 1.2
TIG Rods	5356	X	5 kg packets	1.6, 2.4 and 3.2



Phone for your nearest

ULLRICH ALUMINIUM SALES CENTRE

AUSTRALIA - 1 300 650 075

NEW ZEALAND - 0800 500 338

- ALUMINIUM EXTRUSIONS
- ROLLED PRODUCTS
- FASTENINGS
- LADDERS
- SCAFFOLDS
- ULLTRACLAD CLADDING
- WINTEC WINDOWS & DOORS
- BUILDING PRODUCTS
- DECORATIVE METALS
- TEKNA MACHINERY
- ULLTIMATE SERIES WINDOWS & DOORS

Representative and franchised operations throughout the South Pacific

ULLRICH ALUMINIUM PTY LTD
 PO Box 246 Carole Park Queensland 4300
 20 Ron Boyle Crescent Carole Park Queensland Australia
 Tel +61 7 3718 1400 Fax +61 7 3271 1230
 ullrich@ullrich.com.au www.ullrich.com.au

ULLRICH ALUMINIUM CO LTD
 PO Box 98 843 Manukau
 Auckland 2241 New Zealand
 Tel +64 9 262 6262 Fax +64 9 262 6265
 alkalum@uacl.co.nz www.ullrich.co.nz